



# ODU MINI-SNAP

Miniature Cylindrical Connectors  
with  
Push-Pull-Locking  
Series L, K and B



The latest version of this catalogue  
is posted on our websites:

[www.odu.de](http://www.odu.de)

[www.odu-usa.com](http://www.odu-usa.com)

[www.odu-china.com](http://www.odu-china.com)

**More Push-Pull series see page 137**

**ODU MINI-SNAP is UL-listed under File E110586 00RT03566**

**MIL-Specification: Tests carried out (See page 132).**

All data and specifications subject  
to change without notice.  
All dimensions in mm.  
All pictures are illustrations.

<b>ODU-MINI-SNAP Product Description</b> . . . . .	<b>5</b>
Applications . . . . .	7
Important Issues At A Glance . . . . .	8
Turned contact . . . . .	9
<b>ODU MINI-SNAP Series L</b> . . . . .	<b>11</b>
-The LP Locking Concept. . . . .	12
-Sizes . . . . .	14
<b>-Part Number Key</b> (see also cover) . . . . .	<b>15</b>
-Housings . . . . .	16
-Keyings, Housing Materials/Surfaces, Collet System, Bend Protection Sleeves . . . . .	29
<b>ODU MINI-SNAP Series K</b> . . . . .	<b>35</b>
-The LP Locking Concept. . . . .	36
-Sizes . . . . .	38
<b>-Part Number Key</b> (see also cover) . . . . .	<b>39</b>
-Housings . . . . .	40
-Keyings, Housing Materials/Surfaces, Collet System, Bend Protection Sleeves . . . . .	49
<b>ODU MINI-SNAP Series B</b> . . . . .	<b>53</b>
-The FP Locking Concept. . . . .	54
-Sizes . . . . .	56
<b>-Part Number Key</b> (see also cover) . . . . .	<b>57</b>
-Housings . . . . .	58
-Keyings, Housing Materials/Surfaces, Collet System, Bend Protection Sleeves . . . . .	65
<b>Inserts Series L, K, B</b> . . . . .	<b>71</b>
Insulation Body Material . . . . .	72
Size 00 . . . . .	73
Size 0 . . . . .	74
Size 1 . . . . .	75
Size 2 . . . . .	76
Size 3 . . . . .	78
Size 3 and Size 4. . . . .	79
Size 5 and Size 6. . . . .	80
Contact Type / Contact Surface-Contact Diameter . . . . .	81
Contact Termination Cross Sections . . . . .	82
PCB Layout . . . . .	84
<b>Variations and Special Designs of the ODU-MINI-SNAP</b> . . . . .	<b>93</b>
<b>Accessories</b> . . . . .	<b>97</b>
<b>Tools</b> . . . . .	<b>107</b>
Crimping Tools . . . . .	108
Crimping and Removal Tools for Crimp Contacts (037 and 038) . . . . .	109
Instruction Crimp Tool . . . . .	110
Spanner Wrench. . . . .	111
Removal tool for Crimp-Clip-Contacts. . . . .	112
Assembly tool for series K. . . . .	112

See next page

<b>Assembly Instructions</b> .....	113
Crimping Instructions .....	114
Torque for back-nuts, Cable Preparation .....	120
<b>Technical Information</b> .....	121
International Protection (IP) Classes (DIN EN 60 529) .....	122
Watertightness of the ODU MINI-SNAP .....	123
Operating Voltage acc. to SAE AS 13441-method 3001.1 .....	124
Current Load – Contacts .....	125
Termination Styles .....	126
Conversion Table AWG to Metric .....	127
Housing Materials / Surfaces .....	128
Electromagnetic Compatibility (EMC) .....	129
Autoclaving of ODU MINI-SNAP .....	130
Quality Management .....	131
Tests .....	132
Technical Terms & Definitions .....	133
<b>Inquiry Form (Fax)</b> .....	139

# Product Description



## The ODU MINI-SNAP family of Miniature Cylindrical Connectors features Push-Pull-Locking

Cylindrical Connectors are generally available with several locking mechanisms.

**The most frequently used are:**

- Threaded-Locking Sleeve
- Bayonet-Locking
- Push-Pull-Locking

### **Push-Pull-Connectors have a very simple locking mechanism:**

- As the plug is pushed into the receptacle, locking fingers on the plug snap into the receptacle creating a reliable connection between plug and receptacle.
- Pulling on the cable or the rear of plug causes the locking fingers to grab harder and a separation of plug and receptacle is almost impossible. Pulling on the outer plug housing causes the locking fingers to retract and the plug and receptacle separate easily.

### **The Advantages of Push-Pull-Connectors:**

- Quick and easy mating and demating
- Quick and easy separating
- Easy blind mating in difficult-to-reach places
- Less panel space required
- Definite and secure locking condition
- Less mating required
- Robotic mating and demating possible
- Easy cleaning of housing possible

### **Important Applications for Push-Pull Connectors:**

- Medical Electronics
- Test and Laboratory
- Measurement Instrumentation
- Data and Telecom Systems
- Audio and Video Applications
- Military and Aerospace
- Industrial Controls
- Nuclear Technology

# Applications



Medical

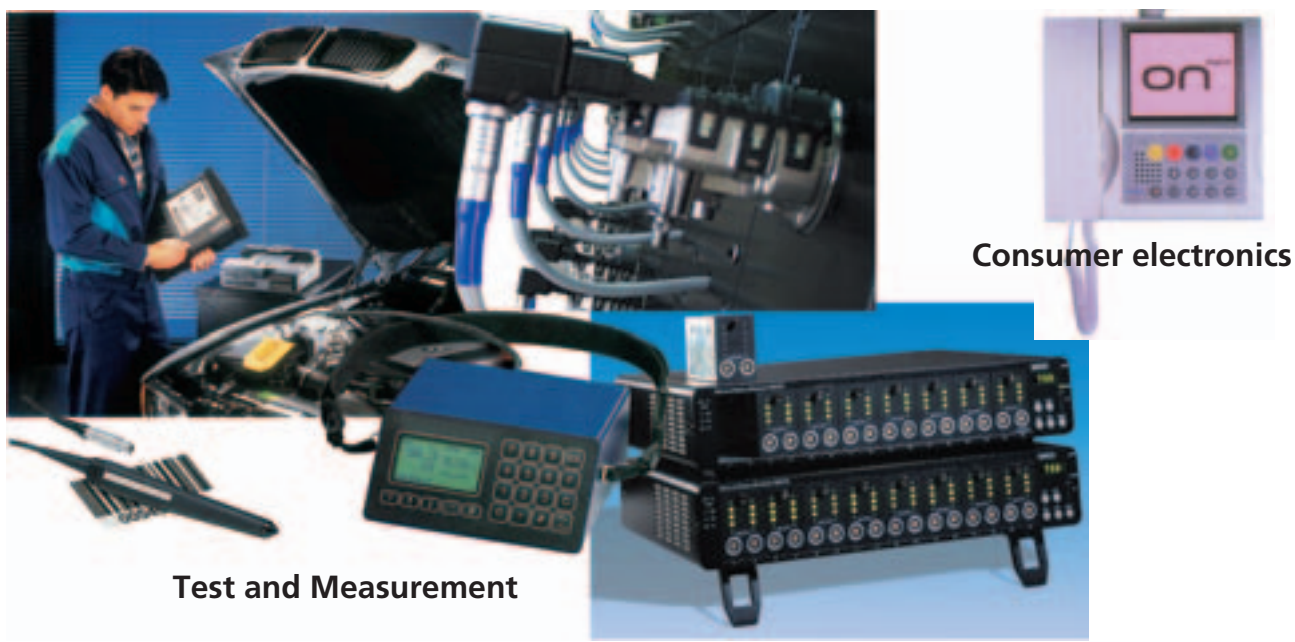

Consumer electronics

Test and Measurement



Telecommunication

Industrial and Automation

## Important Issues At A Glance:

- The series is certified acc. **UL** and VDE.
- **Connector with metal shells available in 8 sizes**  
 Outside diameter between 6.5 mm and 42 mm  
 Number of contact positions: 1 to 40 position, mixed insert arrangements.
- **Plugs and inline receptacles** are offered with solder and crimp termination.  
**Receptacles** are available for solder, crimp, and PCB termination.

- **Applications**

	Insulation Body Material PBT	Material PEEK	Contact Material Ms
General Application requirements (-40 °C +120 °C)	●	●	●
Connectors which, are autoclavable (+134 °C, see page 130)		●	●

- **Termination Style**

- Crimp Termination		●
- Solder Termination	●	●
- Printed Circuit Board (PCB) Termination	●	●

- **Environmental Protection Classification**

IP 50 and IP 68 are available

**➔ What we don't have yet, we can build for you!**

## Turned contact

Turned contacts are available in the diameters 0.5 to 4.0 mm.

The contacts are available with following terminations:

- Solder
- Crimp
- Print

### Standard Pin Contacts

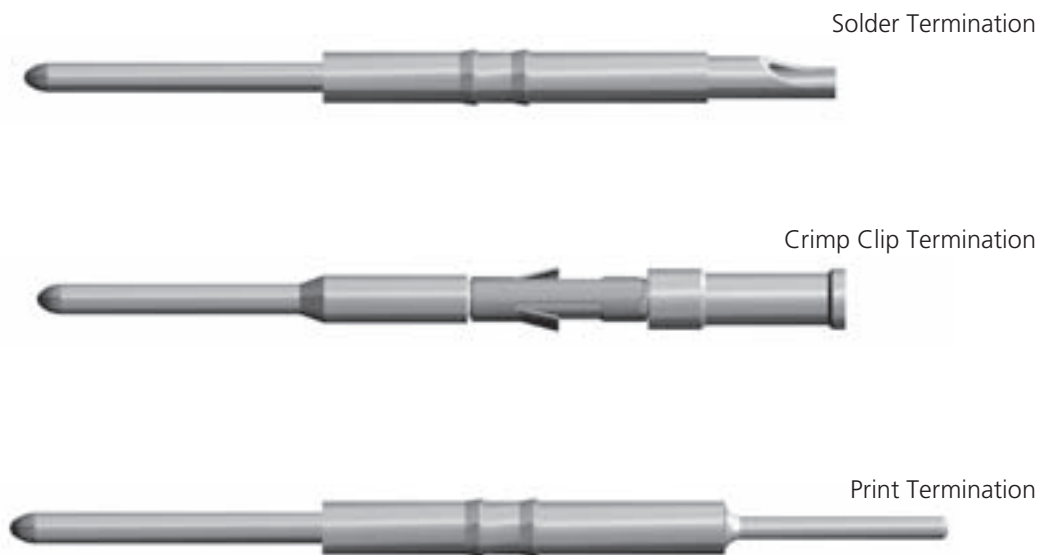

Mating cycles:	> 5,000
Material:	Brass
Treatment processing:	At least. 1.25 $\mu\text{m}$ Ni; at least. 0.75 $\mu\text{m}$ Au on the mating area

**For information regarding diameter, termination style and current load please see the Contact Configuration section.**



# ODU MINI-SNAP



**Series L – IP 50 (and IP 68)**  
LP-Locking Concept  
Keying with Pin and Groove



## The Push-Pull Locking Principle: LP

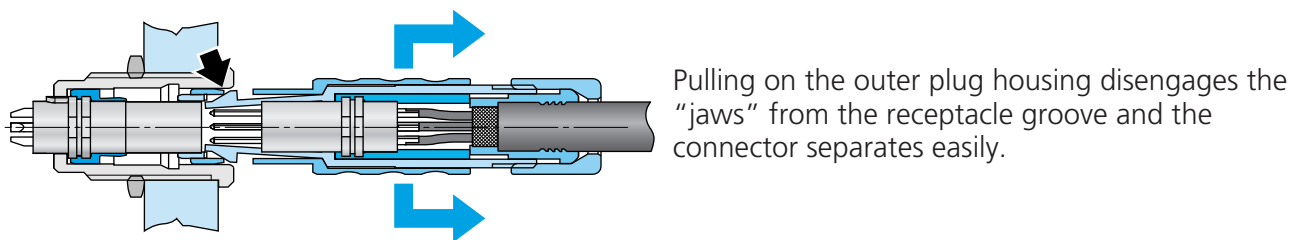
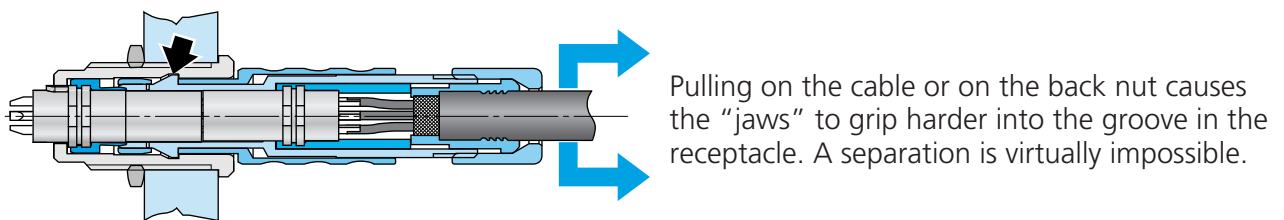
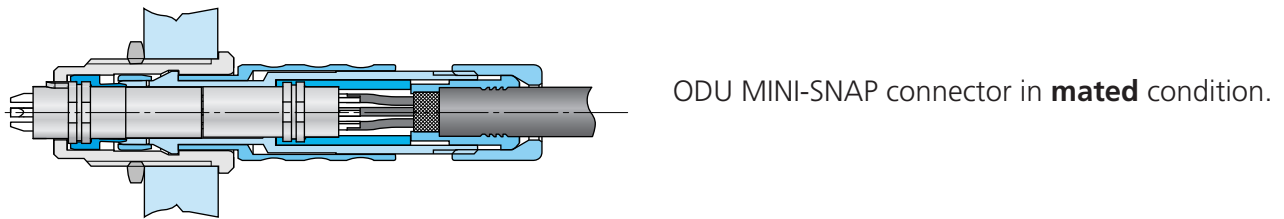
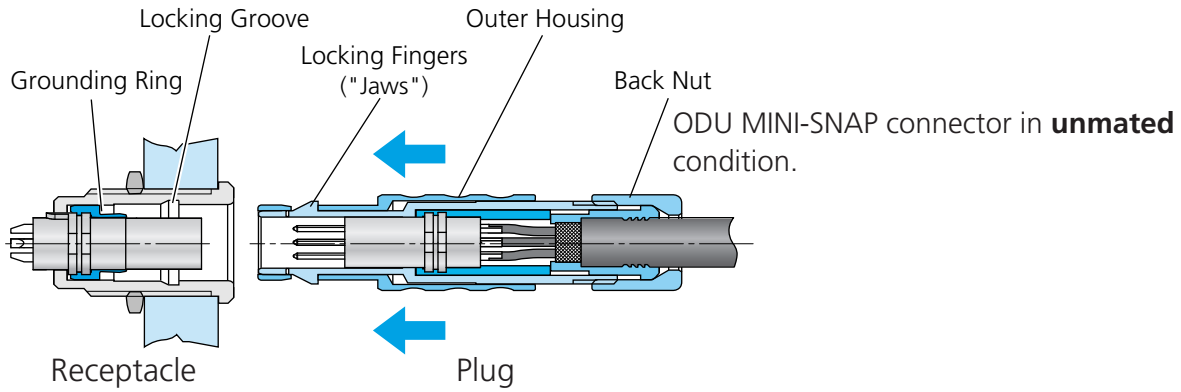

# ODU MINI-SNAP

with LP-Locking Scheme in Cross Section

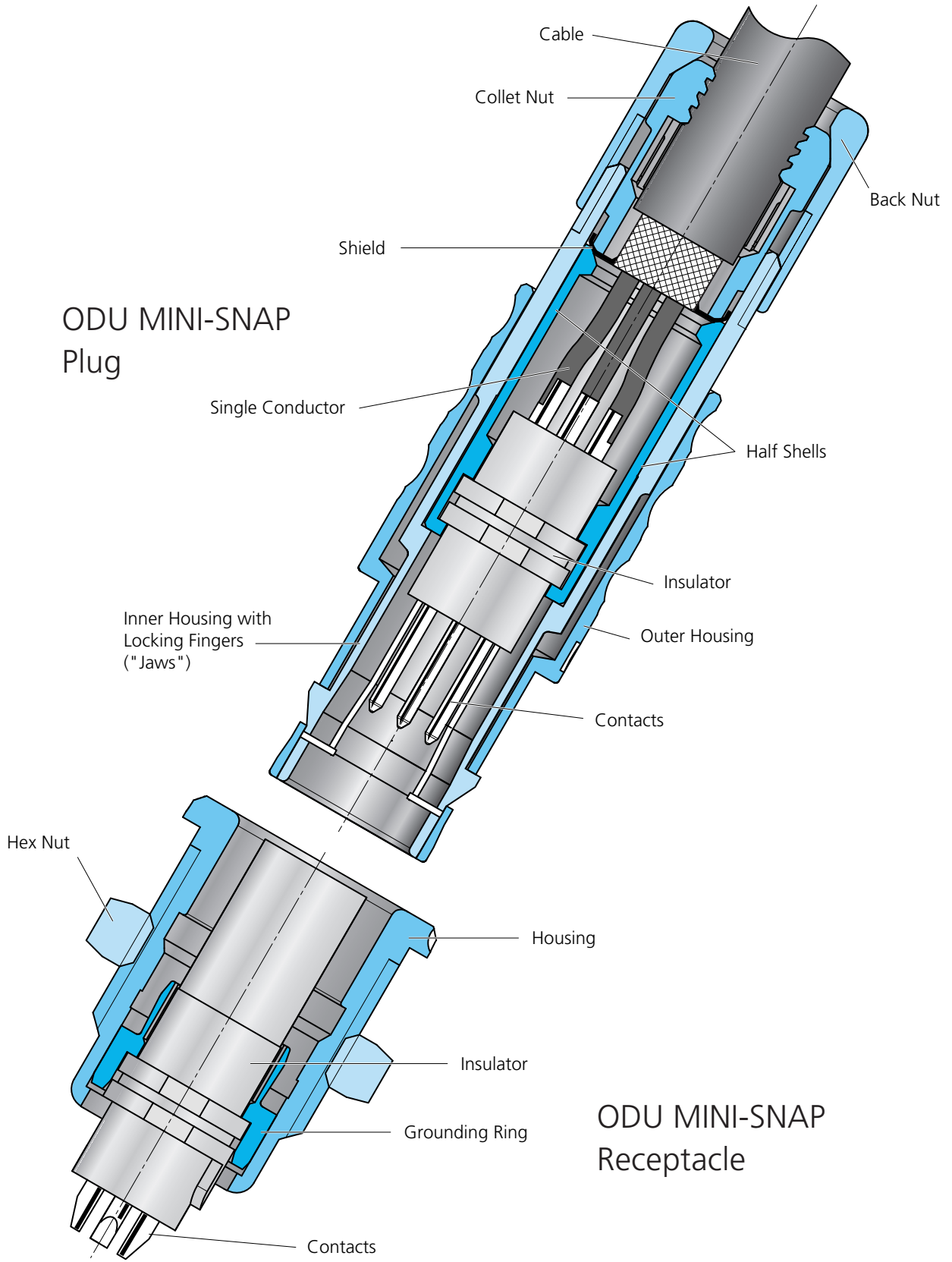

## Available Housing Sizes

(Scale 1 : 1)

**OD** = Outside Diameter (Plug)

**S** = Size

**OD:**

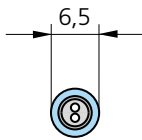

**S:** 00

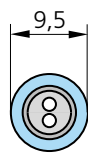

**S:** 0

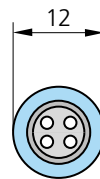

**S:** 1

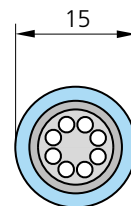

**S:** 2

**OD:**

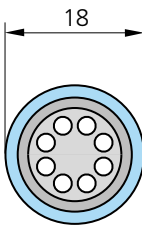

**S:** 3

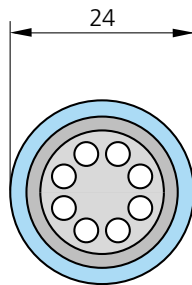

**S:** 4

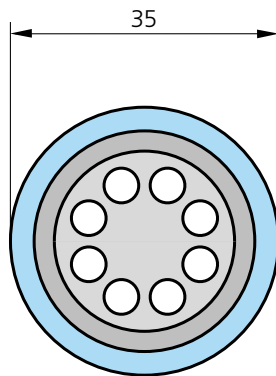

**S:** 5

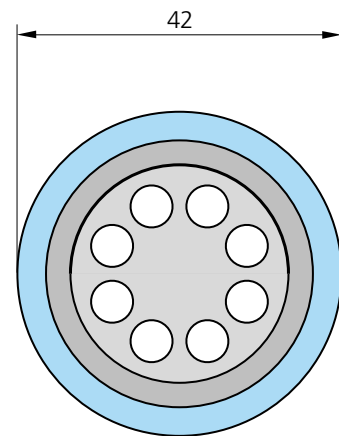

**S:** 6

**Part Number Key**

**The Part number key**

1	2	3	4	5	6	7	8	9	10	11	12	13	14	15	16	17	18	19
			L			-									-			0

Series L

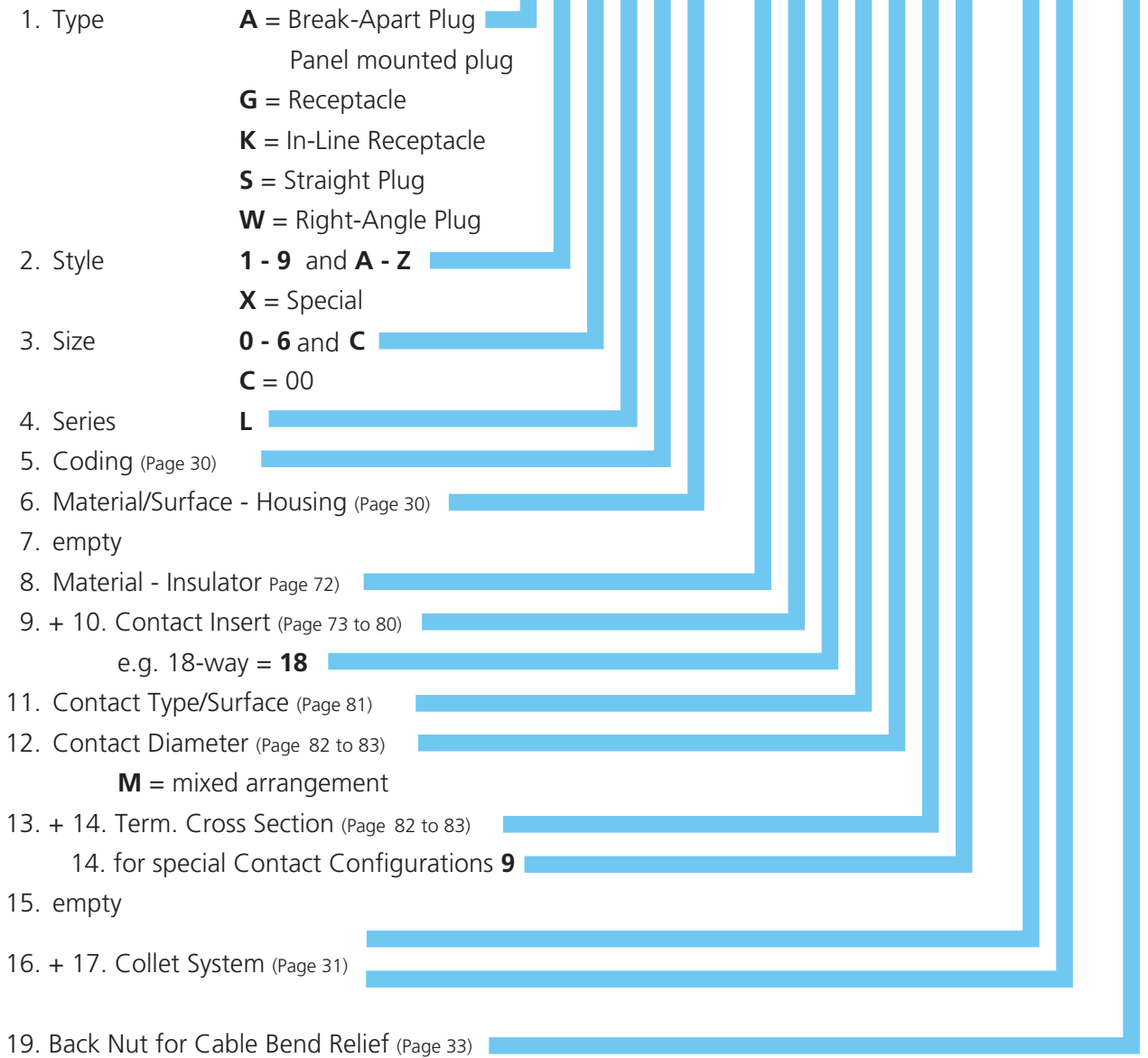

**Example:**

1	2	3	4	5	6	7	8	9	10	11	12	13	14	15	16	17	18	19
G	5	2	L	0	C	-	P	1	6	N	F	G	0	-	0	0	0	0

Receptacle – Style 5 – Size 2 – Series L – Coding 0° – Brass matt chromate Housing – PEEK Insulator – 16-pos. – Socket(crimp) 0.75 µm Au – Term. Cross Section AWG22

1	2	3	4	5	6	7	8	9	10	11	12	13	14	15	16	17	18	19
S	2	2	L	0	C	-	P	1	6	M	F	G	0	-	7	2	0	S

Plug – Style 2 – Size 2 – Series L – Coding 0° – Brass matt chromate Housing – PEEK Insulator – 16-pos. – Pin (solder) 0.75 µm Au – Term. Cross Section AWG22 – Cable Diameter 6.0–7.2 mm – Back Nut for Silicone Cable Bend Relief (Silicone Cable Bend Relief to order separately)

### Part Number Key

1	2	3	4	5	6	7	8	9	10	11	12	13	14	15	16	17	18	19
			L			-								-				0



### Straight Plug

(Suitable for all following receptacles and in-line receptacles)

- S 1** - IP 50 – with Standard Back Nut
- S 2** - IP 50 – with Back Nut for Cable Bend Relief\*

**S 1**

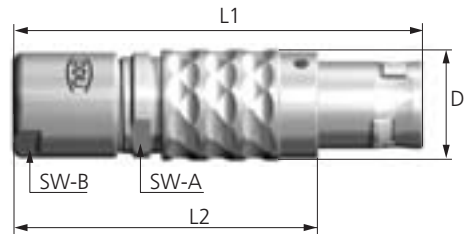

Contact configuration from page 73

**S 2**

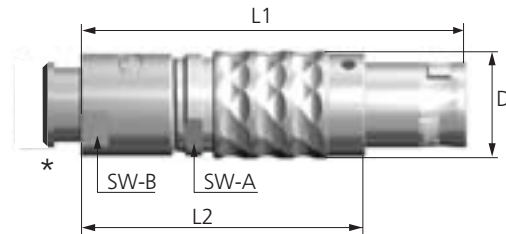

Size	Dimensions in mm				S1 SW-B	S2 SW-B
	L1	L2	D	SW-A		
00	~ 28	~ 20	6.4	5,5	5	5
0	~ 36	~ 26	9	8	7	7
1	~ 43	~ 32	11.5	10	10	10
2	~ 50	~ 38	14.5	13	12	13
3	~ 61	~ 46	17.5	15	14	15
4	~ 76	~ 58	25	21	20	20
5 <sup>1)</sup>	~ 106	~ 81	35	31	30	-
6 <sup>1)</sup>	~ 102	~ 78	42	40	40	-

1) only S1

**\* Cable Bend Reliefs have to be ordered separately.**  
(see page 104)

### Part Number Key

1	2	3	4	5	6	7	8	9	10	11	12	13	14	15	16	17	18	19
			L			-								-				0

## Straight Plug with lanyard for fast demating

(Suitable for all following receptacles and in-line receptacles)

- S 7** - IP 50 – with Standard Back Nut
- S 8** - IP 50 – with Back Nut for Cable Bend Relief\*



Contact configuration from page 73

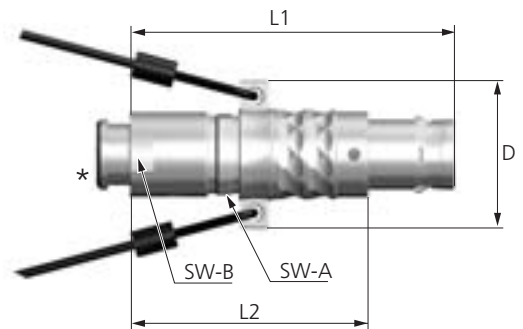
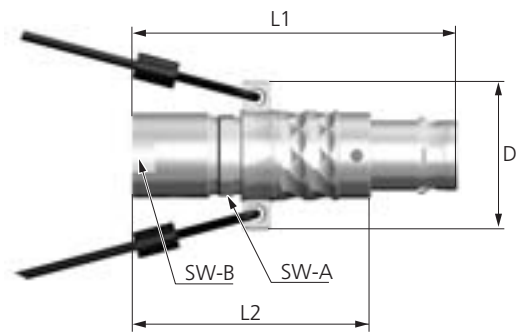

Size	Dimensions in mm				S7		S8
	L1	L2	D	SW-A	SW-B	SW-B	
0	~ 36	~ 26	14.5	8	7	7	
1	~ 43	~ 32	18	10	10	10	
2	~ 50	~ 38	21	13	12	13	
4	~ 76	~ 58	32	21	20	20	
5	~ 106	~ 81	42	31	30	28	

\* Cable Bend Reliefs have to be ordered separately.  
(see page 104)

**Part number key**

1	2	3	4	5	6	7	8	9	10	11	12	13	14	15	16	17	18	19
			L			-								-				0



**Right-Angle Plug**

(Suitable for all following receptacles and in-line receptacles)

- W 1** - IP 50 – with Standard Back Nut
- W 2** - IP 50 – with Back Nut for Cable Bend Relief\*

**W 1**

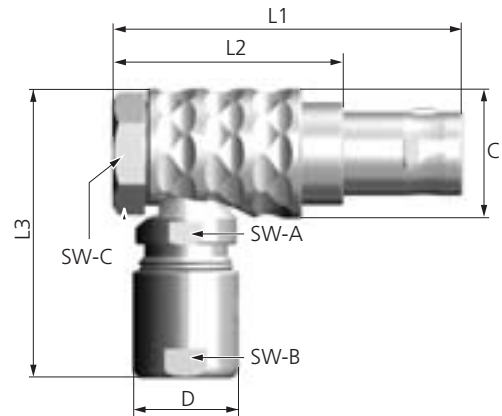

Contact configuration from page 73

**W 2**

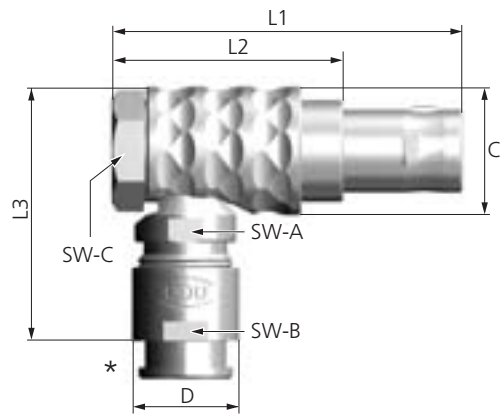

Size	Dimensions in mm						W1	W2	SW-C
	L1	L2	L3	C	D	SW-A	SW-B		
00	~ 24.3	16.3	~ 18.5	7.8	6.4	5.5	5	5	7
0	~ 30	20	~ 22.5	11	9	8	7	7	9
1	~ 36	25	~ 28.5	13.5	11	10	10	10	11
2	~ 41.5	29.5	~ 35	16.5	14	13	12	13	14
3	~ 50	35	~ 36.5	19	16.5	15	14	15	17
4	~ 65	47	~ 52	25	23	21	20	20	22

\* Cable Bend Reliefs have to be ordered separately.  
(see page 104)

**Part number key**

1	2	3	4	5	6	7	8	9	10	11	12	13	14	15	16	17	18	19
			L			-								-				0



**Right-angled Plug (Break-Apart version)** (Suitable for all following receptacles and in-line receptacles)

- W 3** - IP 50 – with Standard Back Nut
- W 4** - IP 50 – with Back Nut for Cable Bend Relief\*

**W 3**

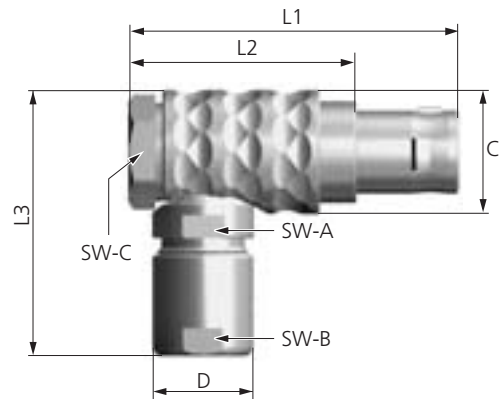

Contact configuration from page 73

**W 4**

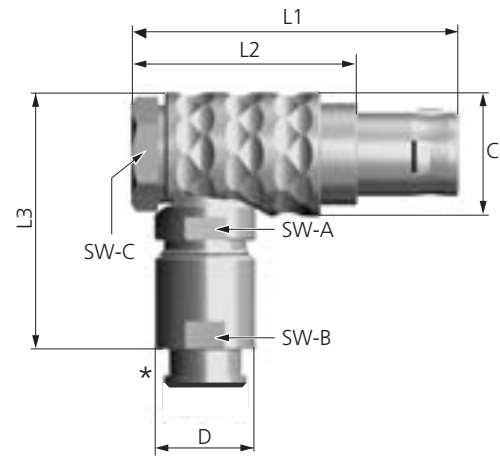

Size	Dimensions in mm						W3	W4	SW-C
	L1	L2	L3	C	D	SW-A	SW-B		
1	~ 36	25	~ 29	13.5	11	10	10	10	11
2	~ 41.5	29.5	~ 35	16.5	14	13	12	13	14

\* **Cable Bend Reliefs have to be ordered separately.**  
(see page 104)

**Part number key**

1	2	3	4	5	6	7	8	9	10	11	12	13	14	15	16	17	18	19
			L			-								-				0



**Break-Apart-Plug (with latching)**

(Suitable for all following receptacles and in-line receptacles)

- A 1** - IP 50 – with Standard Back Nut
- A 2** - IP 50 – with Back Nut for Cable Bend Relief\*

**A 1**



Contact configuration from page 73

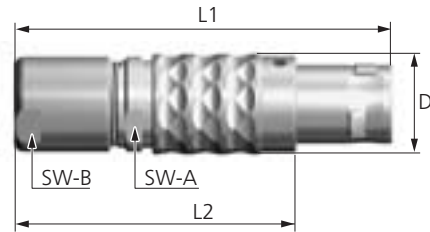

**A 2**

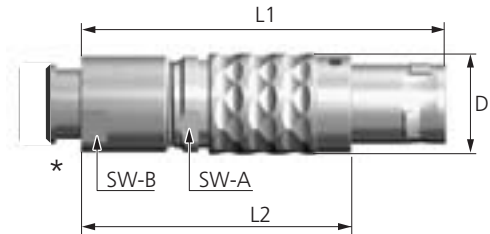

Size	Dimensions in mm				A1	A2
	L1	L2	D	SW-A	SW-B	SW-B
00	~ 28	~ 20	6.4	5.5	5	5
0	~ 36	~ 26	9.0	8	7	7
1	~ 43	~ 32	11.5	10	10	10
2	~ 50	~ 38	14.5	13	12	13

Connector can be separated by pulling the cable.

**\* Cable Bend Reliefs have to be ordered separately.**  
(see page 104)

### Part number key

1	2	3	4	5	6	7	8	9	10	11	12	13	14	15	16	17	18	19
			L			-								-			0	0

<sup>1)</sup> L1 = Maximum Length incl. Contact Insert

## Panel-Mounted Plug

(Suitable for all following receptacles and in-line receptacles)

**A A** - IP 50 – with hex nut, **non-latching**, installation from front of panel

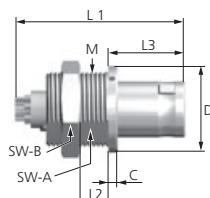

### Technical Data

- IP 50 in mated condition
- anti-rotation feature
- contact configuration and PCB-Layout from page 73

Size	Dimensions in mm								Panel cut-out
	<sup>1)</sup> L1	L2	L3	C	D	SW-A	SW-B	M	
00	~ 17.5	~ 4.5	9	1	8	6.3	9	M7 x 0.5	SW 6.4 / Ø 7.1
0	~ 21	~ 3.5	11.2	1.2	10	8.2	11	M9 x 0.5	SW 8.3 / Ø 9.1
1	~ 26.2	~ 7	12.3	1.5	14	10.5	14	M12 x 1	SW 10.6 / Ø 12.1
2	~ 27.5	~ 7	13.8	1.8	18	13.5	17	M15 x 1	SW 13.6 / Ø 15.1
3	~ 34.5	~ 9	17	2	22	16.5	22	M18 x 1	SW 16.6 / Ø 18.1
4	~ 37.1	~ 8	20.5	2.5	28	23.5	30	M25 x 1	SW 23.6 / Ø 25.1

Created to build up a docking connection between 2 instruments (E.g. a charging station).

**A B** - IP 50 – with hex nut, **latching**, installation from front of panel

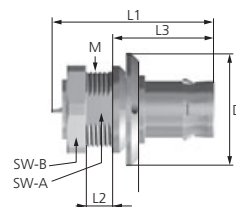

### Technical Data

- IP 50 in mated condition
- anti-rotation feature
- contact configuration and PCB-Layout from page 73

Size	Dimensions in mm							Panel cut-out
	<sup>1)</sup> L1	L2	L3	M	D	SW-A	SW-B	
1	~ 26.2	4	17	12 x 1	18	10.5	14	SW 10.6 / Ø 12.1

Created to build up a docking connection between 2 instruments (E.g. a charging station).

**A D** - IP 68 – with hex nut, **non-latching**, installation from front of panel

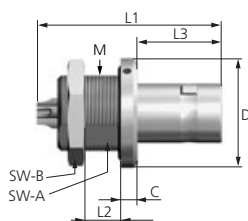

### Technical Data

- IP 68 in mated condition
- anti-rotation feature
- contact configuration and PCB-Layout from page 73
- no crimp contacts possible

Size	Dimensions in mm								Panel cut-out
	<sup>1)</sup> L1	L2	L3	C	D	SW-A	SW-B	M	
0	~ 23.5	~ 5.5	12	2	13	8.2	11	M9 x 0.5	SW 8.3 / Ø 9.1
1	~ 29.5	~ 8	13.3	2.5	17	10.5	14	M12 x 1	SW 10.6 / Ø 12.1
2	~ 29	~ 7	14.8	2.8	19.5	13.5	17	M15 x 1	SW 13.6 / Ø 15.1
3	~ 35	~ 7.5	18	3	24	16.5	22	M18 x 1	SW 16.6 / Ø 18.1

Created to build up a docking connection between 2 instruments (E.g. a charging station).

**Part number key**

1	2	3	4	5	6	7	8	9	10	11	12	13	14	15	16	17	18	19
			L			-								-				0

**In-Line Receptacle**

- K 1** - IP 50 – with Standard Back Nut
- K 2** - IP 50 – with Back Nut for Cable Bend Relief\*

**K 1**



Contact configuration from page 73

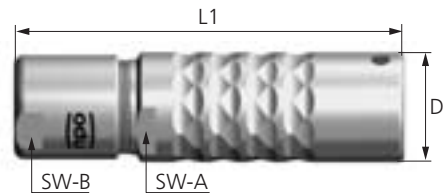

**K 2**

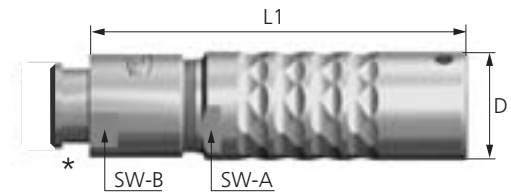

Size	Dimensions in mm			K1 SW-B	K2 SW-B
	L1	D	SW-A		
00	~ 27	6.4	5.5	5	5
0	~ 34.5	9.4	8	7	7
1	~ 41	11.5	10	10	10
2	~ 47	14.5	13	12	13
3	~ 56	17.5	16	14	15
4	~ 74	23.5	21	20	20

\* Cable Bend Reliefs have to be ordered separately.  
(see page 104)

**ODU MINI-SNAP In-line Receptacle connect to plug for cable-to-cable connection.**

### Part number key

1	2	3	4	5	6	7	8	9	10	11	12	13	14	15	16	17	18	19
				L			-								-			0 0

<sup>1)</sup> L1 = Maximum Length incl. Contact Insert  
<sup>2)</sup> L3 = Length of Housing

## Receptacle

**G 1** **Style 1** – ODU MINI-SNAP **RECEPTACLE IP 50**, installation from front of panel

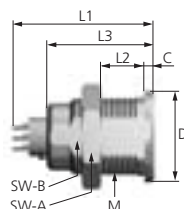

### Technical Data

- IP 50
- anti-rotation feature
- contact configuration and PCB-Layout from page 73

Size	Dimensions in mm									 Panel cut-out
	<sup>1)</sup> L1	L2	<sup>2)</sup> L3	M	D	SW-A	SW-B	C		
00	~ 16.0	~ 7.0	12.0	7x0.5	8.0	9.0	6.3	1.0	SW 6.4 / Ø 7.1	
0	~ 19.5	~ 9.0	14.5	9x0.5	10.0	11.0	8.2	1.5	SW 8.3 / Ø 9.1	
1	~ 24.0	~ 8.0	16.5	12x1	14.0	14.0	10.5	1.5	SW 10.6 / Ø 12.1	
2	~ 27.5	~10.0	18.5	15x1	18.0	17.0	13.5	1.8	SW 13.6 / Ø 15.1	
3	~ 33.0	~13.0	22.5	18x1	22.0	22.0	16.5	2.0	SW 16.6 / Ø 18.1	
4	~ 36.0	~13.0	27.0	25x1	28.0	30.0	23.5	2.5	SW 23.6 / Ø 25.1	
5	~ 43.5	~14	34.0	35x1	40.0	- *	33.5	3.0	SW 33.6 / Ø 35.1	
6	~ 46.0	~18.0	33.0	42x1.5	48.0	48.0	40.0	3.5	SW 40.1 / Ø 42.1	

\* Attention: Size 5 is with a slotted nut instead of a hex nut

**G 5** **Style 5** – ODU MINI-SNAP **RECEPTACLE IP 50**, CONTINUOUS THREAD, installation from rear or front of panel. Front extension adjustable

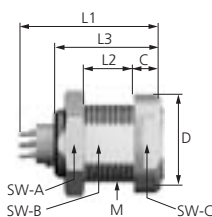

### Technical Data

- IP 50
- anti-rotation feature
- contact configuration and PCB-Layout from page 73

Size	Dimensions in mm									 Panel cut-out
	<sup>1)</sup> L1	L2	<sup>2)</sup> L3	M	D	SW-A	SW-B	SW-C	C	
00	~16.0	~ 6.0	12.0	7x0.5	9.0	9.0	6.3	8.0	2.0	SW 6.4 / Ø 7.1
0	~19.5	~ 8.0	14.5	9x0.5	11.5	11.0	8.2	10.0	2.5	SW 8.3 / Ø 9.1
1	~24.0	~ 8.0	16.5	12x1	15.0	14.0	10.5	13.0	4.0	SW 10.6 / Ø 12.1
2	~27.5	~10.0	18.5	15x1	20.0	17.0	13.5	17.0	4.0	SW 13.6 / Ø 15.1
3	~33.0	~12.0	22.5	18x1	23.0	22.0	16.5	20.0	5.0	SW 16.6 / Ø 18.1
4	~35.0	~10.5	27.0	25x1	30.0	30.0	23.5	27.0	4.5	SW 23.6 / Ø 25.1
5	~43.5	~12.0	34.0	35x1	42.0	- *	33.5	39.0	5.0	SW 33.6 / Ø 35.1

\* Attention: Size 5 is with a slotted nut instead of a hex nut

### Part number key

1	2	3	4	5	6	7	8	9	10	11	12	13	14	15	16	17	18	19
			L			-								-			0	0

<sup>1)</sup> L1 = Maximum Length incl. Contact Insert  
<sup>2)</sup> L3 = Length of Housing

## Receptacle

**G 6** **Style 6** – ODU MINI-SNAP RECEPTACLE IP 50, with round nut, installation from rear or front of panel

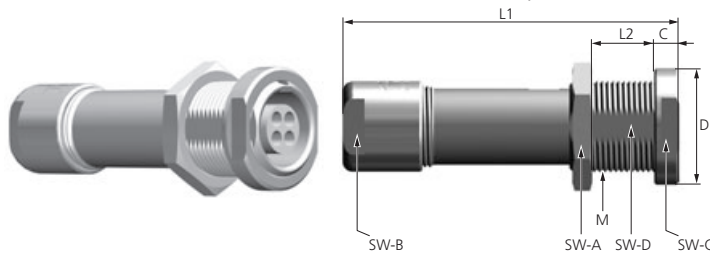

### Technical Data

- IP 50
- anti-rotation feature
- contact configuration from page 73

Size	Dimensions in mm									Panel cut-out
	L1	L2	M	D	SW-A	SW-B	SW-C	SW-D	C	
0	~ 35.0	~ 6.0	9x0.5	11.5	11.0	7.0	10.0	8.2	2.5	SW 8.3 / Ø 9.1
1	~ 41.0	~ 5.0	12x1	15.0	14.0	10.0	13.0	10.5	4.0	SW 10.6 / Ø 12.1
2	~ 48.0	~ 6.5	15x1	20.0	17.0	12.0	17.0	13.5	3.8	SW 13.6 / Ø 15.1

**G 8** **Style 8** – ODU MINI-SNAP WATERTIGHT RECEPTACLE IP 68\*, with slotted nut, installation from rear of panel

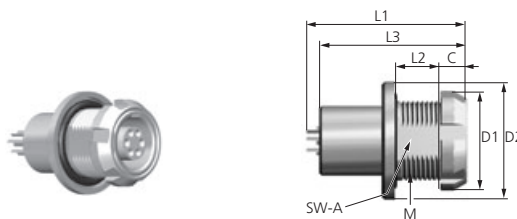

### Technical Data

- IP 68 to the panel in mated or unmated condition
- anti-rotation feature
- contact configuration and PCB-Layout from page 73
- nutdriver for slotted mounting nut, page 111
- no crimp contacts possible

Size	Dimensions in mm								Panel cut-out
	<sup>1)</sup> L1	L2	<sup>2)</sup> L3	M	D1	D2	SW-A	C	
0	~ 22.5	~ 6.0	18.5	9x0.5	12	14	8.2	3	SW 8.3 / Ø 9.1
1	~ 26.0	~ 7.0	22.5	12x1	15.0	18	10.5	4.0	SW 10.6 / Ø 12.1
2	~ 28.0	~ 6.0	23.0	15x1	19.0	20	13.5	4.0	SW 13.6 / Ø 15.1
3	~ 30.0	~ 8.5	26.5	18x1	23.0	24	16.5	5.0	SW 16.6 / Ø 18.1

\* Reference: Potted Receptacle please see page 123

**G A** **Style A** – ODU MINI-SNAP RECEPTACLE IP 50, with round nut, installation from rear of panel

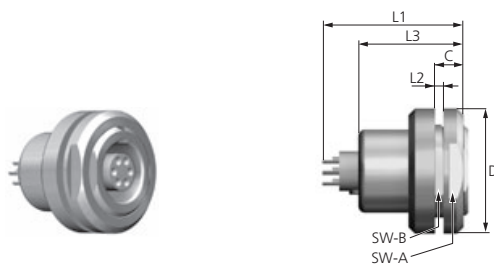

### Technical Data

- IP 50
- anti-rotation feature
- contact configuration and PCB-Layout from page 73

Size	Dimensions in mm								Panel cut-out
	<sup>1)</sup> L1	L2	<sup>2)</sup> L3	M	D	SW-A	SW-B	C	
1	~ 26.0	~ 2.0	16.5	14x1	19.0	17.0	12.0	5.0	SW 12.1 / Ø 14.1
2	~ 29.0	~ 2.0	18.5	16x1	22.0	19.0	15.0	5.0	SW 15.1 / Ø 16.1
3	~ 33.0	~ 2.0	23.5	20x1	27.0	24.0	18.0	6.0	SW 18.1 / Ø 20.1
6	~ 46.0	~ 5.0	33.0	42x1.5	50.0	45.0	40.0	11	SW 40.1 / Ø 42.1

### Part number key

1	2	3	4	5	6	7	8	9	10	11	12	13	14	15	16	17	18	19
			L			-								-			0	0

## Receptacle

**G F** Style F – ODU MINI-SNAP RIGHT-ANGLE RECEPTACLE (without thread)

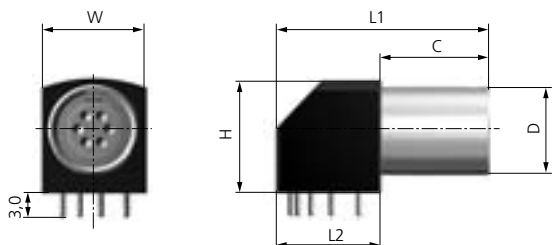

Size	Dimensions in mm						
	L1	L2	C	H	W	D	Maximum Postions
00	17.5	7	10.5	7	7	6.8	4
0	24.8	13.2	11.6	12.7	11.6	9	7
1	26.8	13.2	13.6	14	12.6	11	10

#### Technical Data

- IP 50
- Contact configuration from page 73
- PCB-Layout from page 84–88

### Receptacle for Screw-mounting on the PCB

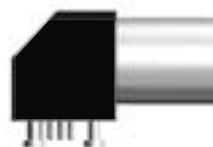

Order informations to the Screw mounting please see page 32

**G G** Style G – ODU MINI-SNAP RIGHT-ANGLE RECEPTACLE (with thread)

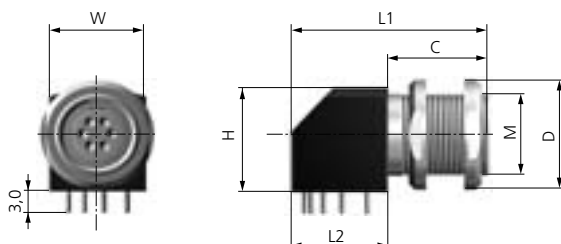

Size	Dimensions in mm							
	L1	L2	C	H	W	M	D	Maximum Postions
0	24.8	13.2	11.6	12.7	11.6	9x0.5	11.5	4
1	26.8	13.2	13.6	14	12.6	11x0.5	14.9	7

#### Technical Data

- IP 50
- Contact configuration from page 73
- PCB-Layout from page 84–88

### Receptacle for Screw-mounting on the PCB



Order informations to the Screw mounting please see page 32

### Part number key

1	2	3	4	5	6	7	8	9	10	11	12	13	14	15	16	17	18	19
			L			-								-			0	0

<sup>1)</sup> L1 = Maximum Length incl. Contact Insert  
<sup>2)</sup> L3 = Length of Housing

## Receptacle

**G H** **Style H** – ODU MINI-SNAP Receptacle IP 50, with low rear profile

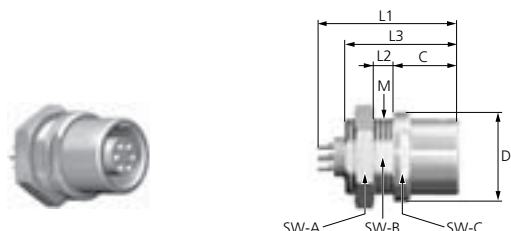

### Technical Data

- IP 50
- anti-rotation feature
- contact configuration and PCB-Layout from page 73

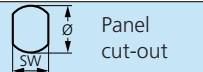
Size	Dimensions in mm									
	<sup>1)</sup> L1	L2	<sup>2)</sup> L3	M	D	SW-A	SW-B	SW-C	C	
00	~ 16.0	~ 2.5	12.5	7x0.5	9.0	9.0	6.3	8.0	8.0	SW 6.4 / ø 7.1
0	~ 21.5	~ 3.5	15.0	9x0.5	11.5	11.0	8.2	10.0	9.0	SW 8.3 / ø 9.1
1	~ 24.0	~ 4.5	17.5	12x1	14.0	14.0	10.5	12.0	10.0	SW 10.6 / ø 12.1
2	~ 26.0	~ 6.0	19.5	15x1	18.0	17.0	13.5	16.0	11.0	SW 13.6 / ø 15.1
3	~ 29.0	~ 6.0	22.5	18x1	22.0	22.0	16.5	-	12.5	SW 16.6 / ø 18.1

**G K** **Style K** – ODU MINI-SNAP Receptacle IP 50, with round nut, installation from rear of panel

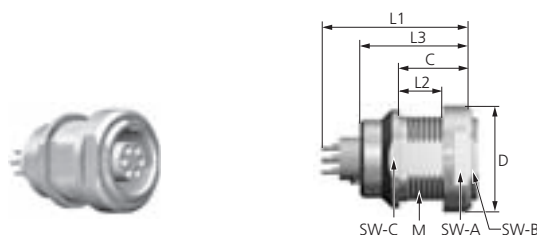

### Technical Data

- IP 50
- anti-rotation feature
- contact configuration and PCB-Layout from page 73

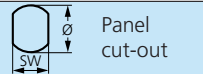
Size	Dimensions in mm									
	<sup>1)</sup> L1	L2	<sup>2)</sup> L3	M	D	SW-A	SW-B	SW-C	C	
0	~ 19.5	~ 3.8	14.5	9x0.5	11.5	10.0	8.2	9.0	6.3	SW 8.3 / ø 9.1
1	~ 24.0	~ 7.0	16.5	12x1	15.0	13.0	10.5	13.0	11.0	SW 10.6 / ø 12.1
2	~ 27.5	~ 5.0	18.5	15x1	20.0	17.0	13.5	15.0	9.0	SW 13.6 / ø 15.1
3	~ 31.0	~ 7.0	22.5	18x1	23.0	20.0	16.5	20.0	12.0	SW 16.6 / ø 18.1
4	~ 35.0	~ 10.0	27.0	25x1	30.0	27.0	23.5	27.0	14.5	SW 23.6 / ø 25.1

**G L** **Style L** – ODU MINI-SNAP Receptacle IP 68, installation from front of panel

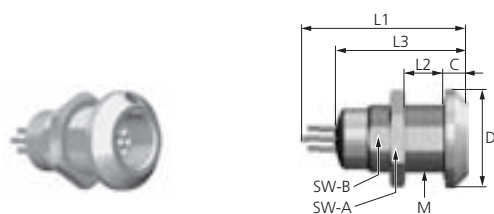

### Technical Data

- IP 68 in reference to the tightness of the end device
- anti-rotation feature
- contact configuration and PCB-Layout from page 73
- no crimp contacts possible

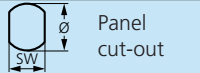
Size	Dimensions in mm								
	<sup>1)</sup> L1*	L2	<sup>2)</sup> L3*	M	D	SW-A	SW-B	C	
00	~ 18	~ 8.0	14.5	7x0.5	11.0	9.0	6.3	1.5	SW 6.4 / ø 7.1
0	~ 21	~ 7.5	16.5	9x0.5	13.0	11.0	8.2	3.0	SW 8.3 / ø 9.1
1	~ 27	~ 9.0	21.5	12x1	16.0	14.0	10.5	4.5	SW 10.6 / ø 12.1
2	~ 29	~ 8.0	24.0	15x1	20.0	17.0	13.5	4.0	SW 13.6 / ø 15.1

\* Reference: Potted receptacle please see page 123

**Part number key**

1	2	3	4	5	6	7	8	9	10	11	12	13	14	15	16	17	18	19
			L			-								-			0	0

**Receptacle**

**G P** Style P – ODU MINI-SNAP PCB Receptacle IP 50

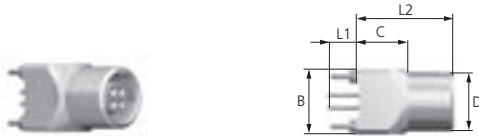

**Technical Data**

- IP 50
- contact configuration from page 73

Size	Dimensions in mm				
	L1	L2	B	C	D
0	4.5	15.0	10.0	8.0	9.0
1	3.6	19.0	12.0	8.0	11.0

PCB-layout on request



# Details for the Part Number Key:

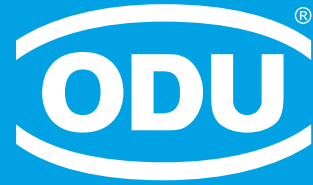
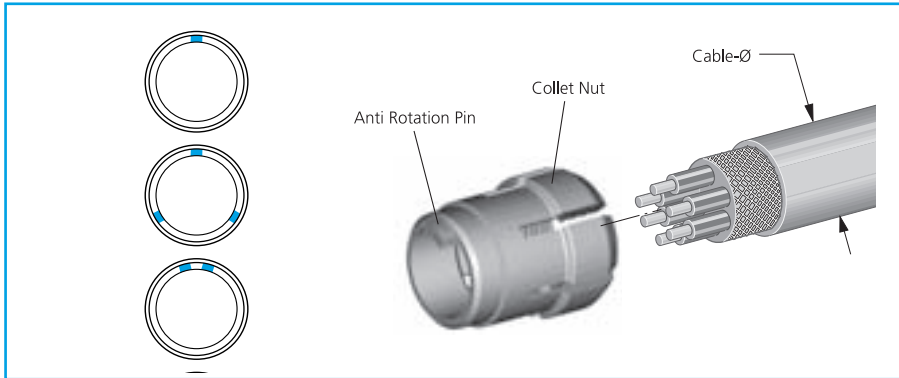

**Keyings**  
**Housing Materials / Surfaces**  
**Collet System**  
**Bend Protection Sleeves**



### Coding

#### Part number key

1	2	3	4	5	6	7	8	9	10	11	12	13	14	15	16	17	18	19
			L		-									-				0



	Angle	Receptacle Front View	Size							
			00	0	1	2	3	4	5	6
<b>O</b>	0°		●	●	●	●	●	●	●	
<b>O</b>	0°									●
<b>A</b>	30°		●	●	●	●	●	○		
<b>B</b>	37.5°					●	●	○		
<b>C</b>	45°					●	●	○		
<b>C</b>	-45°		●	●	●					
<b>F</b>	60°		●	●	●	●	●	○		
<b>J</b>	90°			●	●					
<b>K</b>	95°					●	●	○		
<b>Q</b>	120°					●	●	○		
<b>V</b>	135°			○	●					
<b>W</b>	145°			○	○	●	○	○		
<b>Y</b>	155°		●	●						

● Standard  
○ On Request

### Housing Materials / Surfaces

#### Part number key

1	2	3	4	5	6	7	8	9	10	11	12	13	14	15	16	17	18	19
			L			-								-				



<b>C</b>	<b>Standard</b> Cu-alloy / matt chromate
<b>N</b>	<b>Special materials and surfaces on request.</b> Cu-alloy / nickel
<b>S</b>	Cu-alloy / black chromate

# Collet System

## Part number key

1	2	3	4	5	6	7	8	9	10	11	12	13	14	15	16	17	18	19
			L			-								-				0

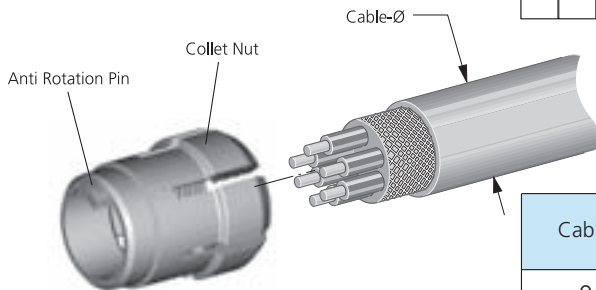

\* It's possible that the collet nut cannot be covered completely over the cable.

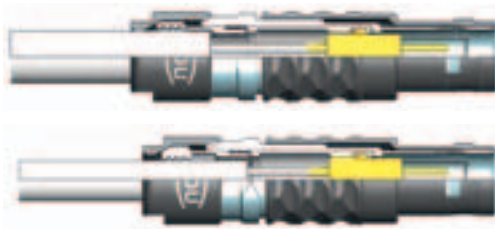

Cable diameter in mm	Size							
	00	0	1	2	3	4	5	6
> 0,5 - 1,0	●							
> 1,0 - 1,5	●							
> 1,5 - 2,0	●							
> 1,5 - 2,2		●	●					
> 2,0 - 2,5	●							
> 2,5 - 3,0	●							
> 2,0 - 3,2		●	●	●				
> 3,0 - 3,5	●*							
> 3,0 - 4,2		●	●	●	●			
> 4,0 - 5,2		●*	●	●	●			
> 5,0 - 5,6		●*						
> 5,0 - 6,2			●	●	●	●		
> 6,0 - 7,2			●*	●	●	●		
> 7,0 - 7,7			○*					
> 7,0 - 8,0						●		
> 7,0 - 8,2				●	●			
> 8,0 - 9,2				●*	●	●		
> 9,0 - 9,9				○*				
> 9,0 - 10,2					●			
> 9,1 - 10,5						●		
> 10,0 - 11,0						●		
> 10,0 - 11,2						●*		
> 11,0 - 11,9						○*	●	
> 12,0 - 13,0							●	●
> 13,0 - 14,0							●	
> 14,0 - 15,0							●*	●
> 15,0 - 16,0							●*	
without collet system								



1	0
1	5
2	0
2	2
2	5
3	0
3	2
3	5
4	2
5	2
5	6
6	2
7	2
7	7
8	0
8	2
9	2
9	9
0	2
0	2
1	1
1	2
1	9
1	3
1	4
1	5
1	6
0	0

Series L

**References:**

○ This diameters are not deliverable for applications with cable bend relief.

**Useable:** for all Plugs and In-Line Receptacles and Receptacle style 6.

**Application:** Collet nut for strain relief.

**Right-Angled Print Contacts in the Receptacle**  
**Part number key**

1	2	3	4	5	6	7	8	9	10	11	12	13	14	15	16	17	18	19
			L			-				Q		0	0	-			0	0



PCB-Layout see Page 84–91  
 Pin version on request

Right-Angled Print Contact

**A**

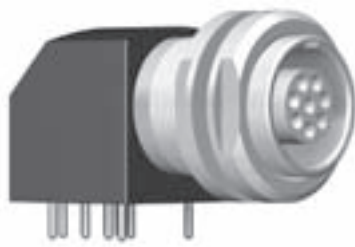

Pin version on request

Receptacle style F and G with  
 4 solder pins  
 (see page 25)

**0**

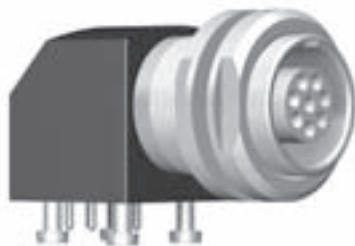

Receptacle style F and G for  
 Screw Mounting  
 (see page 25)

**S**

Max. tightening torque of the screws M1.4: 0.1 Nm

### Definition of the Back Nut

(Straight-Angled-Break Apart Plugs, Inline Receptacles, Receptacles Style 6)

### Part number key

1	2	3	4	5	6	7	8	9	10	11	12	13	14	15	16	17	18	19
			L			-								-			0	



Standard Back Nut

0



Back Nut for Silicon Cable Bend Reliefs

S

Series L

Cable Bend Reliefs on page 104



# ODU MINI-SNAP

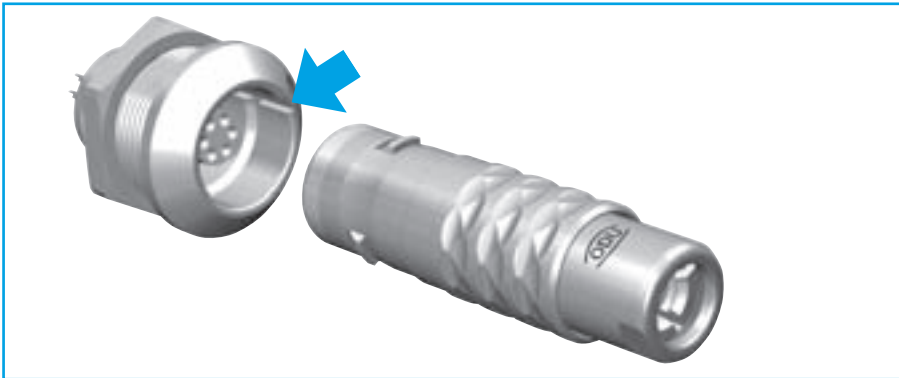

## Series K – IP 68

LP-Locking Concept

Keying with Pin and Groove



## The Push-Pull Locking Principle: LP

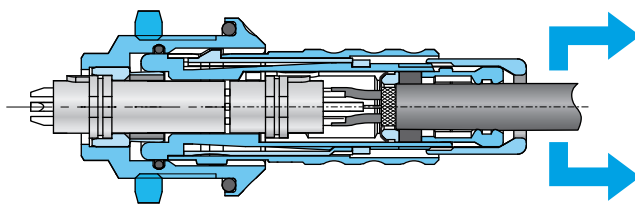
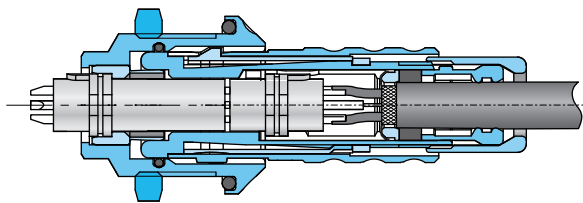
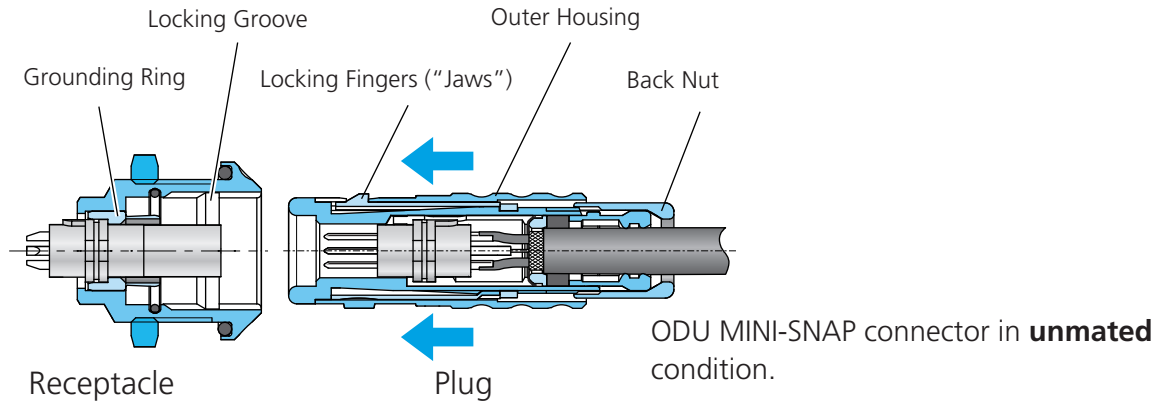

Pulling on the cable or on the back nut causes the "jaws" to grip harder into the groove in the receptacle. A separation is virtually impossible.

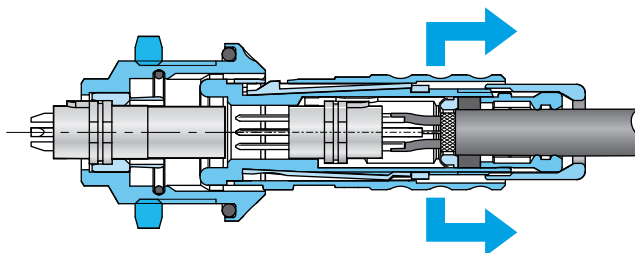

Pulling on the outer plug housing disengages the "jaws" from the receptacle groove and the connector separates easily.

# ODU MINI-SNAP

with LP-Locking Scheme in Cross Section

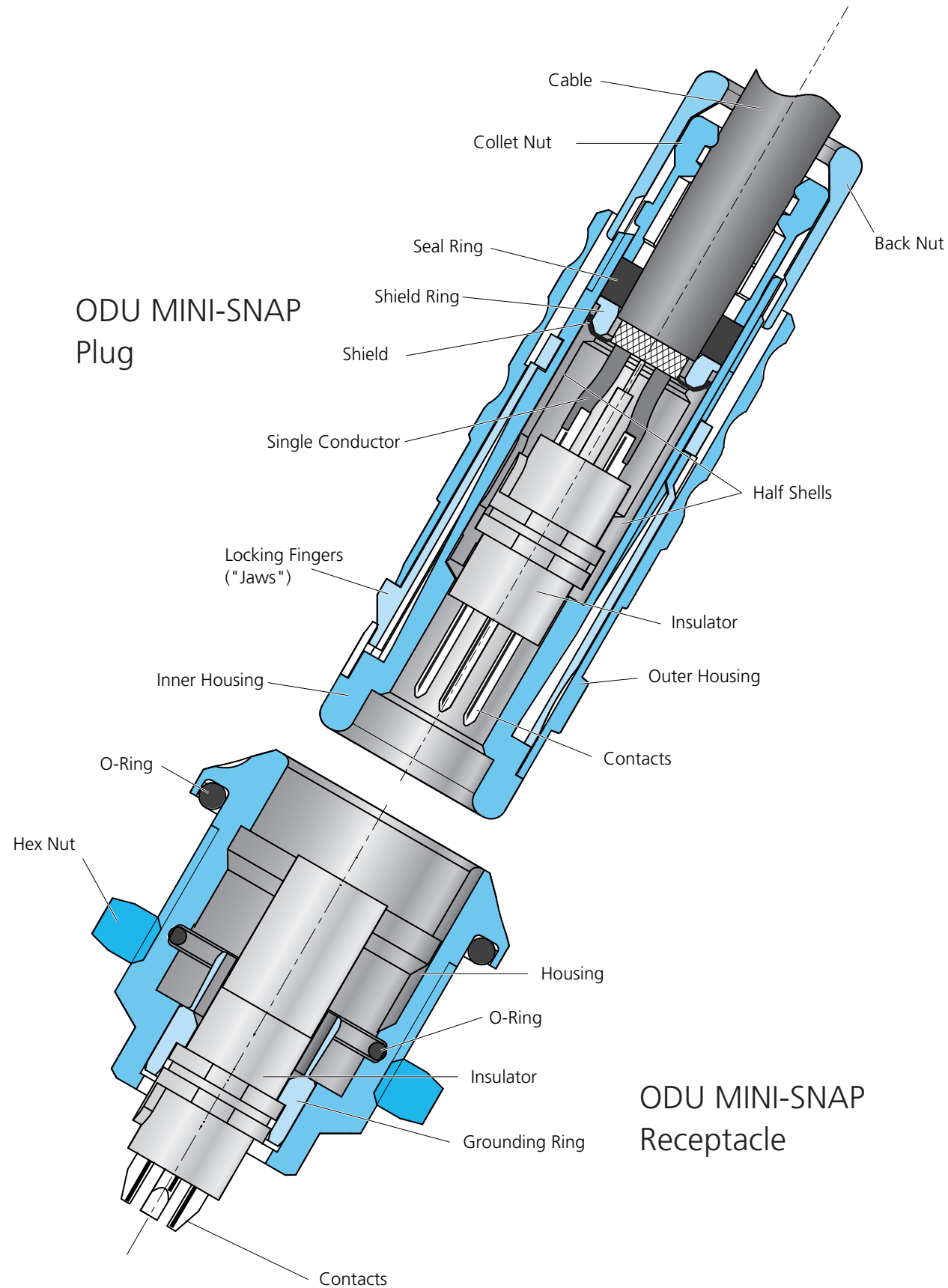

Series K

## Available Housing Sizes

(Scale 1 : 1)

**OD** = Outside Diameter (Plug)  
**S** = Size

**OD:**

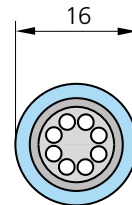
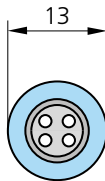
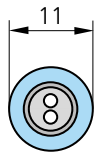

**S:**

0

1

2

**OD:**

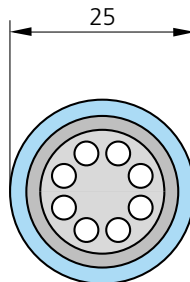
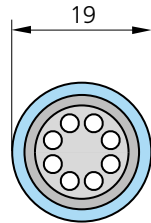

**S:**

3

4

# The Part number key

## Part number key

1	2	3	4	5	6	7	8	9	10	11	12	13	14	15	16	17	18	19
			K			-									-			0

- 1. Type
  - A** = Break-Apart Plug  
Panel mounted plug
  - G** = Receptacle
  - K** = In-Line Receptacle
  - S** = Straight Plug
  - W** = Right-Angle Plug
- 2. Style
  - 1 - 8**
  - X** = Special
- 3. Size
  - 0 - 4**
- 4. Series
  - K**
- 5. Coding (Page 50)
- 6. Material/Surface - Housing (Page 50)
- 7. empty
- 8. Material - Insulator (Page 72)
- 9. + 10. Contact Insert (Page 73 to 80)
  - e.g. 18-way = **18**
- 11. Contact Type/Surface (Page 81)
- 12. Contact diameter (Page 82 to 83)
  - M** = mixed arrangement
- 13. + 14. Term. Cross Section (Page 82 to 83)
  - 14. for special Contact Configurations **9**
- 15. empty
- 16. + 17. Collet System (Page 51)
- 19. Back Nut for Cable Bend Relief (Page 52)

Series K

### Example:

1	2	3	4	5	6	7	8	9	10	11	12	13	14	15	16	17	18	19
G	3	2	K	0	C	-	P	1	6	N	F	G	0	-	0	0	0	0

Receptacle – Style 3 – Size 2 – Series K – Coding 0° – Brass matt chromate Housing – PEEK Insulator – 16-pos. – Socket(crimp) 0.75 µm Au –Term. Cross Section AWG22

1	2	3	4	5	6	7	8	9	10	11	12	13	14	15	16	17	18	19
S	2	2	K	0	C	-	P	1	6	M	F	G	0	-	7	0	0	S

Plug – Style 2 – Size 2 – Series K – Coding 0° – Brass matt chromate Housing – PEEK Insulator – 16-pos. – Pin (solder) 0.75 µm Au – Term. Cross Section AWG22 – Cable Diameter 6.5–7.0 mm – Back Nut for Silicone Cable Bend Relief (Cable Bend Relief to order separtly)

**Part number key**

1	2	3	4	5	6	7	8	9	10	11	12	13	14	15	16	17	18	19
			K			-								-				0



**Straight Plug**

(Suitable for all following receptacles and in-line receptacles)

- S 1** - IP 68 – with Standard Back Nut
- S 2** - IP 68 – with Back Nut for Cable Bend Relief\*

**S 1**



Contact configuration from page 73

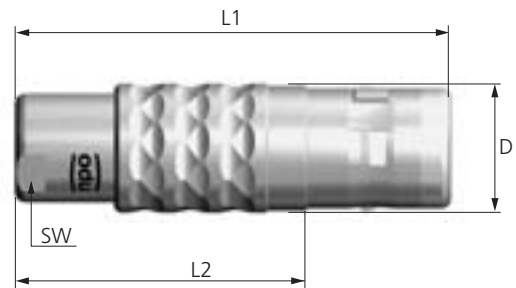

**S 2**

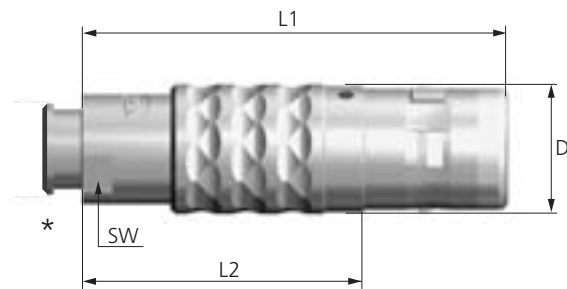

Size	Dimensions in mm			S1	S2
	L1	L2	D	SW	SW
0	~ 37	~ 25	11	7	7
1	~ 44	~ 27	13	10	10
2	~ 50	~ 33	16	12	13
3	~ 60	~ 40	19	14	15
4	~ 70	~ 49	25	20	20

**\* Cable Bend Reliefs have to be ordered separately.**  
(see page 104)

### Part number key

1	2	3	4	5	6	7	8	9	10	11	12	13	14	15	16	17	18	19
			K			-								-				0

### Break-Apart-Plug

- A 1** - IP 68 – with Standard Back Nut
- A 2** - IP 68 – with Back Nut for Cable Bend Relief\*



**A 1**

Contact configuration from page 73



**A 2**

Connector can be separated by pulling the cable.

\* Cable Bend Reliefs have to be ordered separately (see page 104).

Size	Dimensions in mm			A1	A2
	L1	L2	D	SW	SW
0	~ 37	~ 25	11	7	7
1	~ 44	~ 27	13	10	10
3	~ 60	~ 40	19	14	15

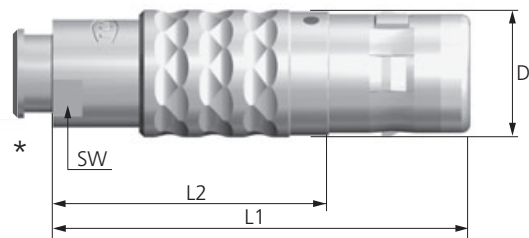
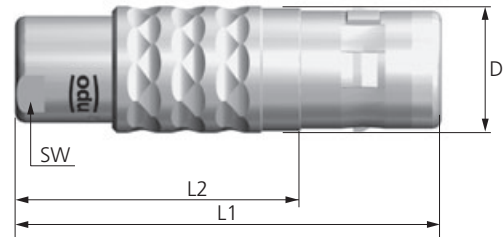

### Panel-Mounted Plug

- A A** - IP 68 – with hex nut, non-latching, installation from front of panel

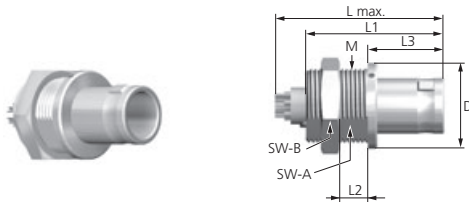

#### Technical Data

- IP 68 in mated condition
- anti-rotation feature
- contact configuration and PCB-Layout from page 73

Size	Dimensions in mm								Panel cut-out
	L max.	L1	L2	L3	M	D	SW-A	SW-B	
1	28	23.5	~ 4	16.3	16x1	19.9	14.5	18.5	SW 14.6 / Ø 16.1
2	32	28	~ 4.5	19	20x1	24.9	18.5	25	SW 18.6 / Ø 20.1

- A D** - IP 68 – with hex nut, non-latching, installation from front of panel

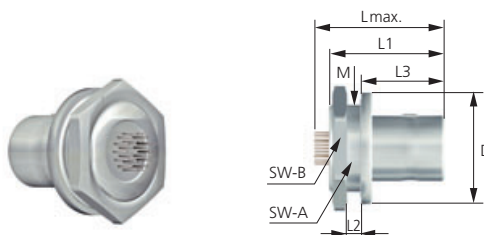

#### Technical Data

- IP 68 in reference to the tight of the end device and in unmated condition
- anti-rotation feature
- crimp contacts not possible
- contact configuration and PCB-Layout from page 73

Size	Dimensions in mm								Panel cut-out
	L max.	L1	L2	L3	M	D	SW-A	SW-B	
3	36	32.2	~ 4	23.2	24x1.0	31	22.5	30	SW 22.6 / Ø 24.1

Created to build up a docking connection between 2 instruments (E.g. a charging station).

## Part number key

1	2	3	4	5	6	7	8	9	10	11	12	13	14	15	16	17	18	19
			K			-								-				0



## Right-Angle Plug

(Suitable for all following receptacles and in-line receptacles)

- W 1** - IP 68 – with Standard Back Nut
- W 2** - IP 68 – with Back Nut for Cable Bend Relief\*

IP 68

**W 1**

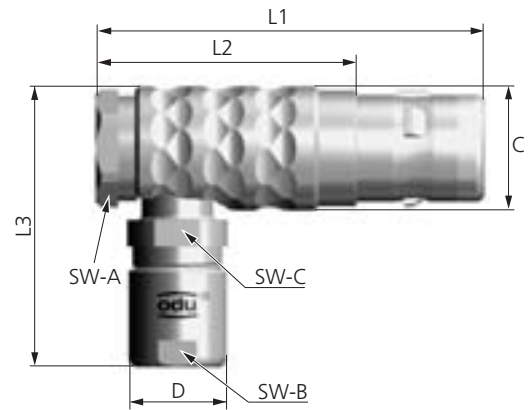

Contact configuration from page 73

**W 2**

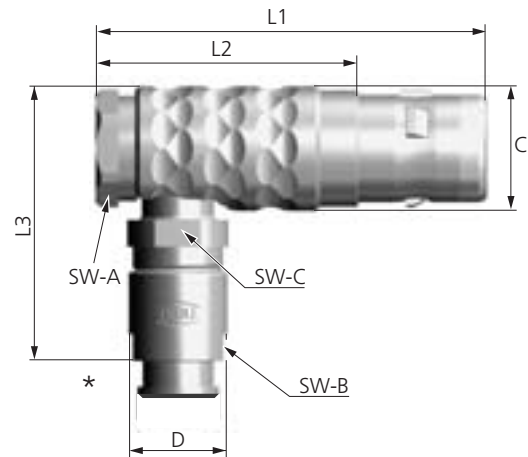

Size	Dimensions in mm						W1	W2	SW-C
	L1	L2	L3	C	D	SW-A	SW-B		
0	~ 34.7	23.2	~ 27	11.5	9	10	7	7	8
1	~ 43	28.7	~ 33	14	11	12	10	10	10
2	~ 51	35	~ 37	17.5	14	15	12	13	13
3	~ 60	40	~ 43	20	16.5	18	14	15	15

\* Cable Bend Reliefs have to be ordered separately.  
(see page 104)

**Part number key**

1	2	3	4	5	6	7	8	9	10	11	12	13	14	15	16	17	18	19
			K			-								-				0

**In-Line Receptacle**

- K 1** - IP 68 – with Standard Back Nut
- K 2** - IP 68 – with Back Nut for Cable Bend Relief\*

**K 1**



Contact configuration from page 73

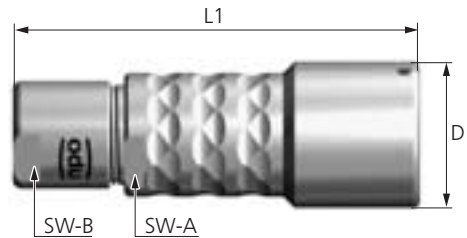

**K 2**

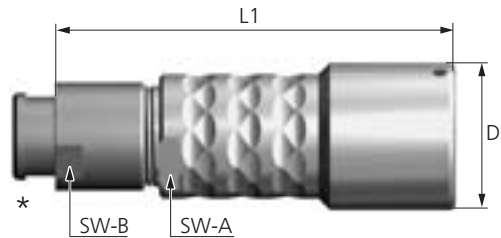

Size	Dimensions in mm			K1	K2
	L1	D	SW-A	SW-B	SW-B
0	~ 38	13	9	7	7
1	~ 46	15	11	10	10
2	~ 54	19	14	12	13
3	~ 64	23	16.5	14	15
4	~ 74	29	20	20	20

\* Cable Bend Reliefs have to be ordered separately.  
(see page 104)

**ODU MINI-SNAP In-line Receptacle connect to plug for cable-to-cable connection**

**Part number key**

1	2	3	4	5	6	7	8	9	10	11	12	13	14	15	16	17	18	19
			K			-								-			0	0

<sup>1)</sup> L1 = Maximum Length incl. Contact insert  
<sup>2)</sup> L3 = Length of Housing

**Receptacle**

**G 1** **Style 1** – ODU MINI-SNAP RECEPTACLE IP 68, installation from front of panel

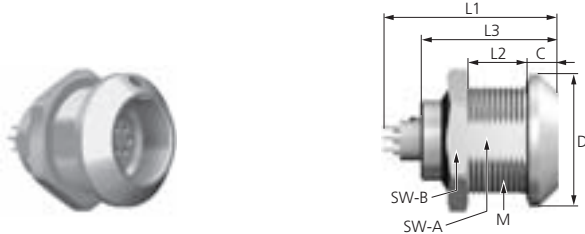

**Technical Data**

- IP 68 in mated condition
- anti-rotation feature
- contact configuration and PCB-Layout from page 73

Size	Dimensions in mm								Panel Cut-Out
	<sup>1)</sup> L1	L2	<sup>2)</sup> L3	M	D	C	SW-A	SW-B	
0	20.7	~ 5.5	15.5	14x1	18	4.0	12.5	17	SW 12.6 / Ø 14.1
1	28	~ 9	20.5	16x1	20	4.5	14.5	19	SW 14.6 / Ø 16.1
2	31	~ 9	23	20x1	25	5	18.5	29	SW 18.6 / Ø 20.1
3	36	~ 11	28	24x1	31	6	22.5	30	SW 22.6 / Ø 24.1
4	39.5	~ 11	31.5	30x1	40.5	6.5	28.5	36	SW 28.6 / Ø 30.1

**G 3** **Style 3** – ODU MINI-SNAP RECEPTACLE IP 68 WITH SLOTTED MOUNTING NUT, installation from rear of panel

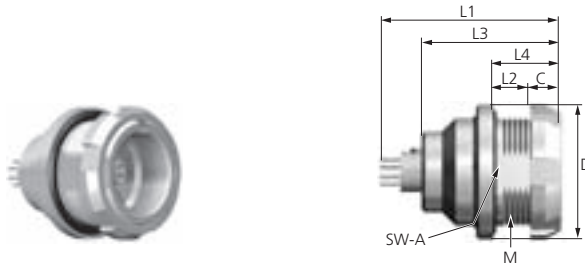

**Technical Data**

- IP 68 in mated condition
- anti-rotation feature
- contact configuration and PCB-Layout from page 73
- Nutdriver, page 111

Size	Dimensions in mm								Panel Cut-Out
	<sup>1)</sup> L1	L2	<sup>2)</sup> L3	L4	M	D	C	SW-A	
0	21	~ 3.0	15.5	7	14x1	18	4.0	12.5	SW 12.6 / Ø 14.1
1	28	~ 6.2	20.5	10	16x1	20	3.5	14.5	SW 14.6 / Ø 16.1
2	31	~ 6.2	23	10	20x1	25	3.5	18.5	SW 18.6 / Ø 20.1
3*	36	~ 7.5	28	12	24x1	31	4.5	22.5	SW 22.6 / Ø 24.1
4	40	~ 6.5	31.5	13.5	30x1	41.5	7.0	28.5	SW 28.6 / Ø 30.1

\* Reference: Size 3 with round nut SW 27

**G 4** **Style 4** – ODU MINI-SNAP WATERTIGHT RECEPTACLE IP 68\*, installation from front of panel with low rear profile

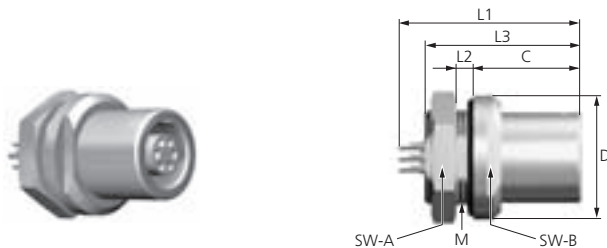

**Technical Data**

- IP 68 in reference to the end device and in unmated condition \*
- Anti-rotation feature
- contact configuration and PCB-Layout from page 73
- \* No crimp contacts possible – only Solder- and Print design can be used here

Size	Dimensions in mm								Panel Cut-Out
	<sup>1)</sup> L1	L2	<sup>2)</sup> L3	M	D	SW-A	SW-B	C	
1	~ 28.0	~ 1.5	20.5	16x1	20	19	17	15.5	SW 14.6 / Ø 16.1
2	~ 32	~ 2	23	20x1	25	24	20	17	SW 18.6 / Ø 20.1

\*Reference: Potted Receptacle please see page 123 III

Part number key

1	2	3	4	5	6	7	8	9	10	11	12	13	14	15	16	17	18	19
			K			-								-			0	0

<sup>1)</sup> L1 = Maximum Length incl. Contact Insert  
<sup>2)</sup> L3 = Length of Housing

**Receptacle**

**G 6**

**Style 6** – ODU MINI-SNAP Receptacle IP 68, WITH STRAIN RELIEF, installation of rear of panel

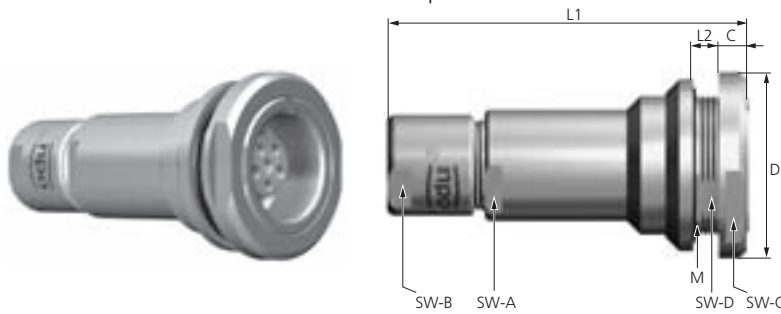

Technical Data

- IP 68 in mated condition
- anti-rotation feature
- Contact configuration from page 73

Size	Dimensions in mm										Panel Cut-Out
	L1	L2	M	D	C	SW-A	SW-B	SW-C	SW-D		
1	~ 48	~ 7	16x1	22	3	11	10	19	14.5	SW 14.6 / Ø 16.1	
2	~ 54	~ 4	20x1	27	4	14	12	24	18.5	SW 18.6 / Ø 20.1	
3	~ 64	~ 6	24x1	31	4.5	16.5	14	27	22.5	SW 22.6 / Ø 24.1	

**G 7**

**Style 7** – ODU MINI-SNAP RECEPTACLE IP 68, WITH STRAIN RELIEF, installation from front of panel

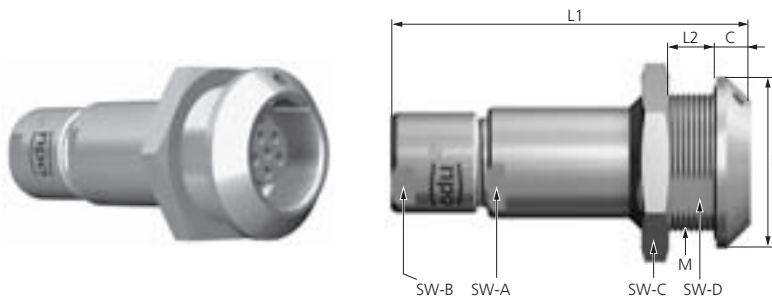

Technical Data

- IP 68 in mated condition
- anti-rotation feature
- Contact configuration from page 73

Size	Dimensions in mm										Panel Cut-Out
	L1	L2	M	D	C	SW-A	SW-B	SW-C	SW-D		
2	~ 54	~ 9	20x1	25	5	14	12	24	18.5	SW 18.6 / Ø 20.1	

**G 8**

**Style 8** – ODU MINI-SNAP RECEPTACLE IP 68, with slotted mounting nut, installation from rear of panel

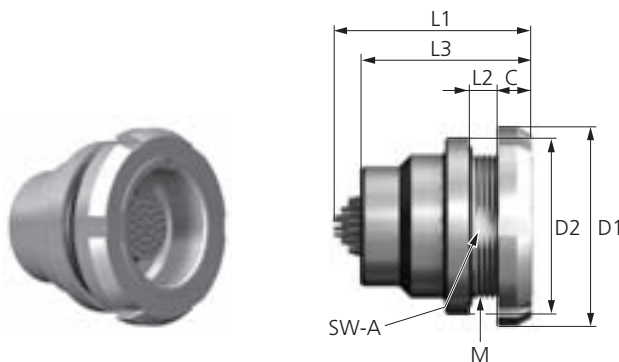

Technical Data

- IP 68 in reference to the end device in unmated condition
- anti-rotation feature
- Crimp contacts not possible
- Contact configuration from page 73

Size	Dimensions in mm									Panel Cut-Out
	<sup>1)</sup> L1	L2	<sup>2)</sup> L3	M	D1	D2	C	SW-A		
1	~ 31	~ 6	26.6	16x1	20	20	3.5	14.5	SW 14.6 / Ø 16.1	
2	~ 34	~ 6	27	20x1	25	25	3.5	18.5	SW 18.6 / Ø 20.1	
3*	~ 39	~ 7	32.7	24x1	30	31	4.5	22.5	SW 22.6 / Ø 24.1	
4	~ 41	~ 6	35.5	30x1	41.5	36.9	7	28.5	SW 28.6 / Ø 30.1	

\* Reference: Size 3 with round nut SW 27

**Part number key**

1	2	3	4	5	6	7	8	9	10	11	12	13	14	15	16	17	18	19
			K			-								-			0	0

<sup>1)</sup> L1 = Maximum Length incl. Contact Insert

<sup>2)</sup> L3 = Length of Housing

**Receptacle**

**G L**

**Style L** – ODU MINI-SNAP **RECEPTACLE IP 68**, installation from front of panel

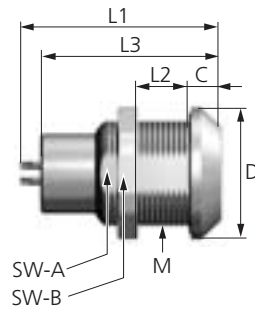

**Technical Data**

- IP 68 in reference to the end device in unmated condition
- anti-rotation feature
- Crimp contacts not possible
- Contact configuration from page 73

Size	Dimensions in mm								 Panel Cut-Out
	<sup>1)</sup> L1	L2	<sup>2)</sup> L3	M	D	C	SW-A	SW-B	
0	~ 24	~ 5	19.7	14x1	18	4	12.5	17	SW 12.6 / Ø 14.1
1	~ 30	~ 9	26.6	16x1	20	4.5	14.5	19	SW 14.6 / Ø 16.1
2	~ 32	~ 9	27	20x1	25	5	18.5	24	SW 18.6 / Ø 20.1





# Details for the Part Number Key:

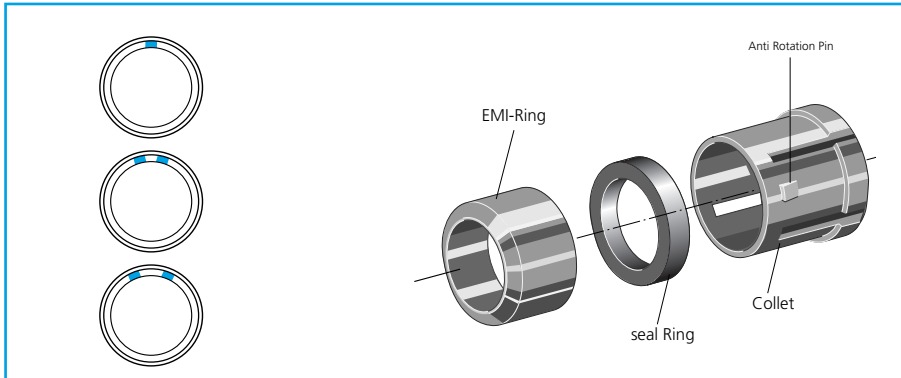

**Keying**  
**Housing Materials / Surfaces**  
**Collet System**  
**Bend Protection Sleeves**



### Coding

#### Part number key

1	2	3	4	5	6	7	8	9	10	11	12	13	14	15	16	17	18	19
			K		-									-				

	Angle	Receptacle Front View	Size				
			0	1	2	3	4
<b>0</b>	0°		●	●	●	●	●
<b>A</b>	30°		●	●	●	○	○
<b>C</b>	45°		●	●	●	○	○
<b>F</b>	60°		●	●	●	○	○
<b>H</b>	75°		○	○	○	○	○
<b>K</b>	95°		○	○	○	○	○
<b>Q</b>	120°		○	○	○	○	○
<b>W</b>	145°		○	○	○	○	○

● Standard  
○ On request

### Housing Materials / Surfaces

#### Part number key

1	2	3	4	5	6	7	8	9	10	11	12	13	14	15	16	17	18	19
			K			-								-				0

<b>C</b>	<b>Standard</b> Cu-alloy / matt chromate
<b>Special materials and surfaces on request.</b>	
<b>N</b>	Cu-alloy / nickel
<b>S</b>	Cu-alloy / black chromate

## Collet System Part number key

1	2	3	4	5	6	7	8	9	10	11	12	13	14	15	16	17	18	19
			K			-								-				0

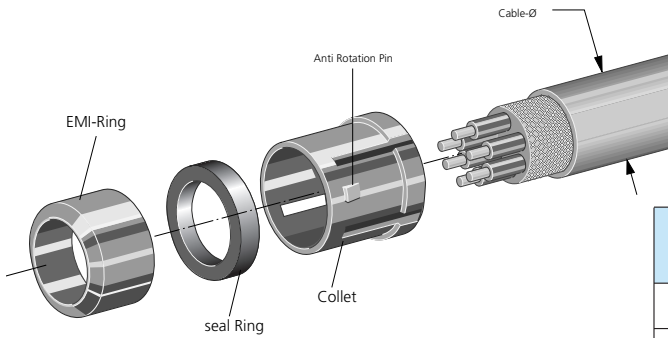

**Useable:** for all Plugs and In-Line Receptacles.

**Application:** Collet nut for strain relief.

**Reference:** ❶ This application is not available for applications with cable bend relief.

Cable diameter in mm	Size				
	0	1	2	3	4
> 1.5 – 2.0	●	❶			
> 2.0 – 2.5	●	●			
> 2.5 – 3.0	●	●	●		
> 3.0 – 3.5	●	●	●	●	
> 3.5 – 4.0	●	●	●	●	
> 4.0 – 4.5	●	●	●	●	
> 4.5 – 5.0	●	●	●	●	
> 5.0 – 5.5		●	●	●	
> 5.5 – 6.0		●	●	●	
> 6.0 – 6.5		●	●	●	
> 6.5 – 7.0		●	●	●	
> 7.0 – 7.5			●	●	
> 7.5 – 8.0			●	●	
> 8.0 – 8.5			●	●	
> 8.5 – 9.0			●	●	
> 9.0 – 9.5				●	●
> 9.5 – 10.0				●	
> 10.0 – 10.5				●	●
> 10.5 – 11.5					●
> 13.5 – 14.0					●
without cable collet					



### Right-Angled Print Contacts in the Receptacle

#### Part number key

1	2	3	4	5	6	7	8	9	10	11	12	13	14	15	16	17	18	19
			K			-				Q		0	0	-			0	0

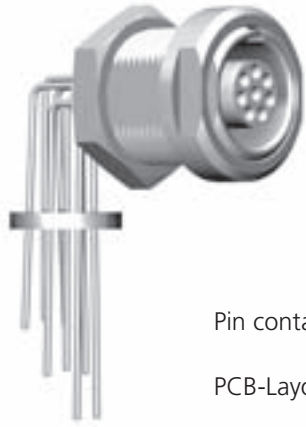

Right-Angled Print Contact

Pin contacts on request!

PCB-Layout see Page 84–91



A

### Definition of the Back Nut

(Straight-Angled-Break Apart Plugs, Inline Receptacles, Receptacles Style 6 & 7)

#### Part number key

1	2	3	4	5	6	7	8	9	10	11	12	13	14	15	16	17	18	19
			K			-								-			0	



Standard Back Nut

Back Nut for Silicon Cable Bend Reliefs



0

S

Cable Bend Reliefs on page 104

# ODU MINI-SNAP



## Series B – IP68

FP-Locking Concept

Keying with Pin and Groove



## The Push-Pull Locking Principle: FP

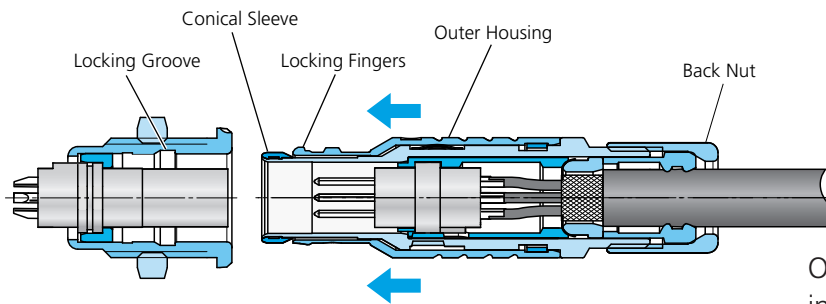

ODU MINI-SNAP connector in **unmated** condition.

Receptacle

Plug

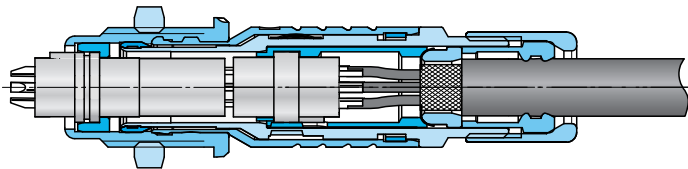

ODU MINI-SNAP connector in **mated** condition.

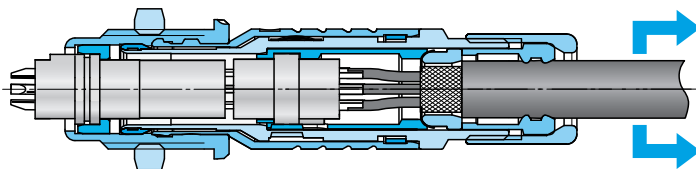

Pulling on the cable or on the back nut causes the locking fingers to grip tighter into the groove inside the receptacle. A separation is virtually impossible.

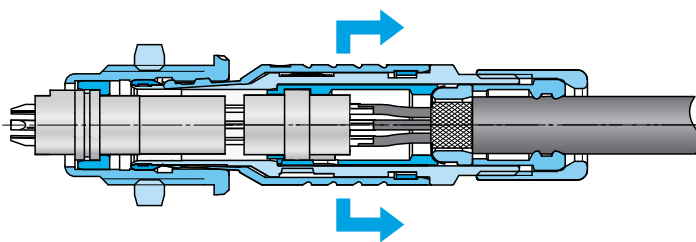

Pulling on the outer plug housing disengages the locking fingers from the receptacle groove and the connector separates easily.

# ODU MINI-SNAP

with FP-Locking Scheme in Cross Section

ODU MINI-SNAP  
Plug

ODU MINI-SNAP  
Receptacle

Series B

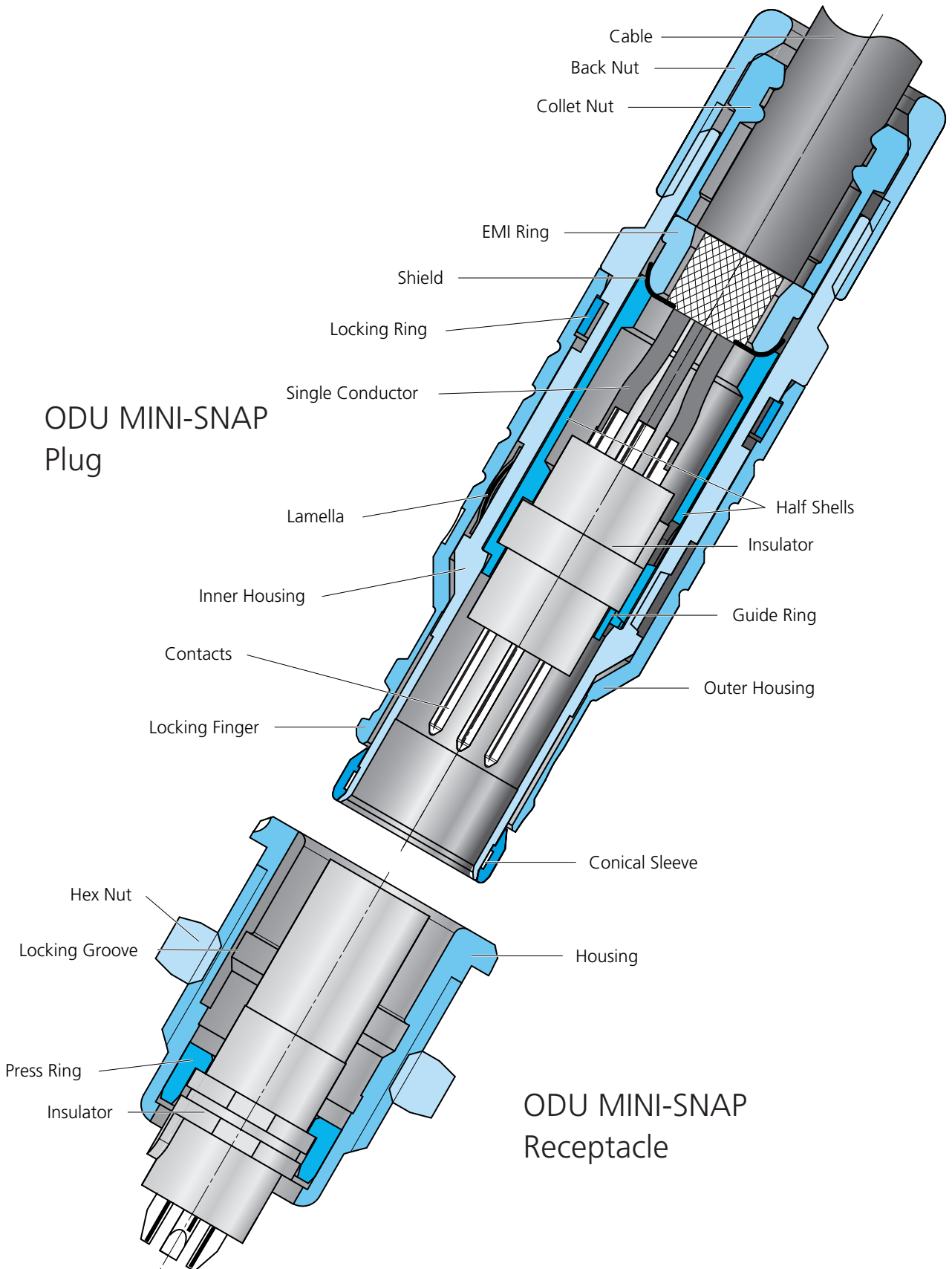

## Available Housing Sizes

(Scale 1 : 1)

**OD** = Outside Diameter (Plug)

**S** = Size

**OD:**

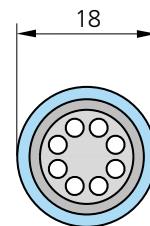
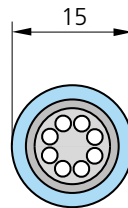
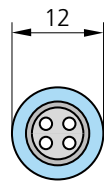
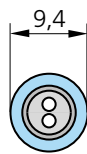

**S:**

0

1

2

3

# The Part Number Key

## Part number key

1	2	3	4	5	6	7	8	9	10	11	12	13	14	15	16	17	18	19	
			<b>B</b>			-									-				

- 1. Type **A = Break-Apart Plug**  
**G = Receptacle**  
**K = In-Line Receptacle**  
**S = Straight Plug**  
**W = Right-Angle Plug**
- 2. Style **1 - 9 and A - Z**  
**X = Special**
- 3. Size **0 - 3**
- 4. Series **B**
- 5. Coding (Page 66)
- 6. Material/Surface - Housing (Page 67)
- 7. empty
- 8. Material - Insulator Page 72)
- 9. + 10. Contact Insert (Page 73 to 80)  
e.g. 18-way = **18**
- 11. Contact Type/Surface (Page 81)
- 12. Contact Diameter (Page 82 to 83)  
**M = mixed arrangement**
- 13. + 14. Term. Cross Section (Page 82 to 83)  
14. for special Contact Configurations **9**
- 15. empty
- 16. + 17. Collet System (Page 68)
- 18. + 19. Cable Bend Relief (Page 70)

**Example:**

1	2	3	4	5	6	7	8	9	10	11	12	13	14	15	16	17	18	19
<b>G</b>	<b>2</b>	<b>2</b>	<b>B</b>	<b>0</b>	<b>C</b>	-	<b>P</b>	<b>1</b>	<b>6</b>	<b>N</b>	<b>F</b>	<b>G</b>	<b>0</b>	-	<b>0</b>	<b>0</b>	<b>0</b>	<b>0</b>

Receptacle – Style 2 – Size 2 – Series B – Coding 0° – Brass matt chromate Housing – PEEK Insulator – 16-pos. – Socket(crimp) 0.75 µm Au – Term. Cross Section AWG22

1	2	3	4	5	6	7	8	9	10	11	12	13	14	15	16	17	18	19
<b>S</b>	<b>4</b>	<b>2</b>	<b>B</b>	<b>0</b>	<b>C</b>	-	<b>P</b>	<b>1</b>	<b>6</b>	<b>M</b>	<b>F</b>	<b>G</b>	<b>0</b>	-	<b>7</b>	<b>5</b>	<b>E</b>	<b>S</b>

Plug – Style 4 – Size 2 – Series B – Coding 0° – Brass matt chromate Housing – PEEK Insulator – 16-pos. – Pin (solder) 0.75 µm Au – Term. Cross Section AWG22 – Cable Diameter 7.0–7.5 – Blue Cable Bend Relief – Material Silicone

**Part number key**

1	2	3	4	5	6	7	8	9	10	11	12	13	14	15	16	17	18	19
			B			-								-				



**Straight Plug**

(Suitable for all following receptacles and in-line receptacles)

- S 3** - IP 68 – watertight with Standard Back Nut
- S 4** - IP 68 – watertight with Back Nut for Cable Bend Relief\*

Contact configuration from page 73

**IP 68**

**S 3**

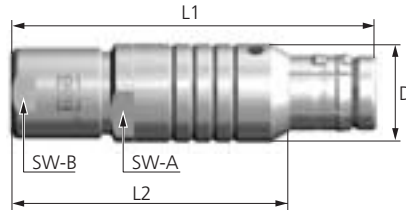

**S 4**

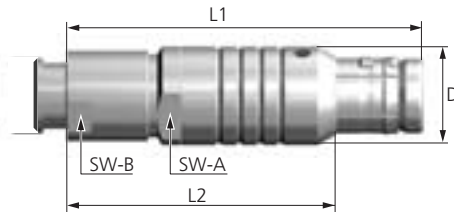

**IP 68**

Size	Dimensions in mm				S3	S4
	L1	L2	D	SW-A	SW-B	SW-B
0	~ 40	~ 28	9.4	8	7	7
1	~ 49	~ 36	12	10	10	10
2	~ 53	~ 39	15	13	12	13
3	~ 61	~ 46	18	16	15	15

\* **Cable Bend Reliefs**  
(see page 70)

**Part number key**

1	2	3	4	5	6	7	8	9	10	11	12	13	14	15	16	17	18	19
			B			-								-				



**Right-Angle Plug**

(Suitable for all following receptacles and in-line receptacles)

- W 3** - IP 68 – watertight with Standard Back Nut
- W 4** - IP 68 – watertight with Back Nut for Cable Bend Relief\*

Contact configuration from page 73

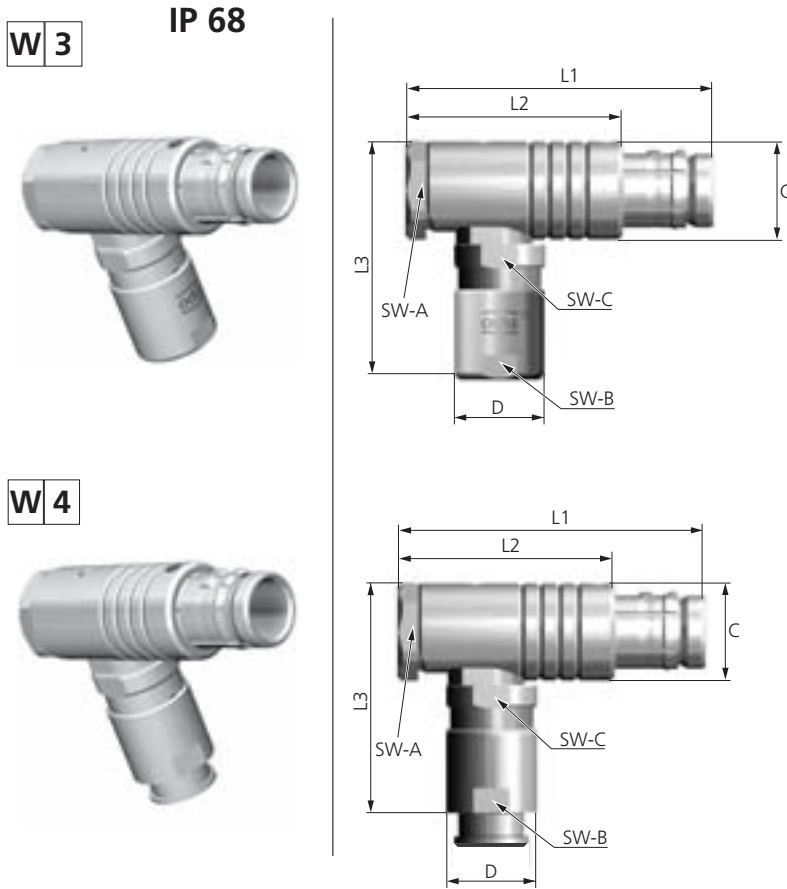

**IP 68**

Size	Dimensions in mm						W3	W4	SW-C
	L1	L2	L3	C	D	SW-A	SW-B		
0	~ 34	~ 24	~ 30	12	9	10	7	7	8
1	~ 42	~ 31.5	~ 32	12.5	11	11	10	10	10
2	~ 46	~ 34	~ 39	16	14	14	12	13	13
3	~ 60	~ 45	~ 41	18	17	16	15	15	16

\* **Cable Bend Reliefs**  
(see page 70)

Assembly Tool Size 0: 700.412.106.000.000

**Part number key**

1	2	3	4	5	6	7	8	9	10	11	12	13	14	15	16	17	18	19
				B			-							-				



**Break-Apart-Plug**

- A 5** - IP 68 – with Standard Back Nut
- A 6** - IP 68 – with Back Nut for Cable Bend Relief\*

(Suitable for all following receptacles and in-line receptacles)

**IP 68**

**A 5**



Contact configuration from page 73

**A 6**

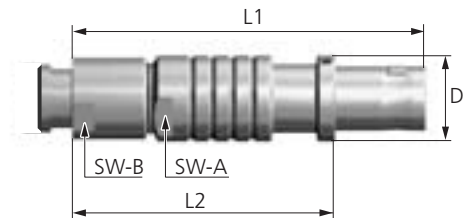
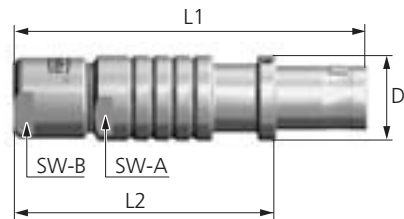

Size	Dimensions in mm				
	L1	L2	D	SW-A	SW-B
0	~ 39.5	~ 29.5	9.4	8	7

Connector can be separated by pulling the cable.

\* **Cable Bend Reliefs**  
(see page 70)

**Part number key**

1	2	3	4	5	6	7	8	9	10	11	12	13	14	15	16	17	18	19
			B			-								-				



**In-Line Receptacle**

- K 3** - IP 68 – watertight with Standard Back Nut
- K 4** - IP 68 – watertight with Back Nut for Cable Bend Relief\*

Contact configuration from page 73

**K 3**

**IP 68**

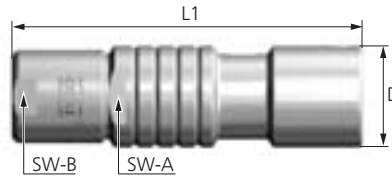

**K 4**

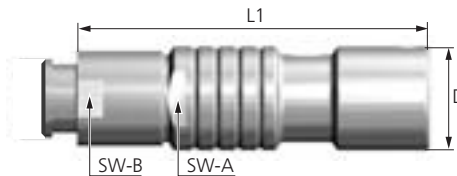

**IP 68**

Size	Dimensions in mm			K3		K4
	L1	D	SW-A	SW-B	SW-B	
0	~ 39	10	8	7	7	
1	~ 46	13	10	10	10	
2	~ 50	16	13	12	13	
3	~ 60	19	16	15	15	

\* **Cable Bend Reliefs**  
(see page 70)

**ODU MINI-SNAP In-line Receptacle connect to plug for cable-to-cable connection.**

Part number key

1	2	3	4	5	6	7	8	9	10	11	12	13	14	15	16	17	18	19
				B			-								-			

<sup>1)</sup> L1 = Maximum Length incl. Contact Insert  
<sup>2)</sup> L3 = Length of Housing

**Receptacle**

**G 2** **Style 2** – ODU MINI-SNAP WATERTIGHT RECEPTACLE IP 68\*, installation from front of panel

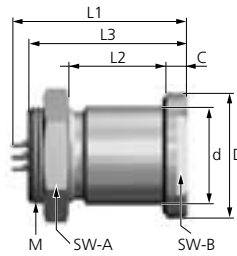

Technical Data

- IP 68 in reference to the end device and in mated condition
- contact configuration and PCB-Layout from page 73
- distance ring for wall-thickness adjustment, see page 106
- no crimp contacts possible

Size	Dimensions in mm										Panel Cut-Out
	<sup>1)</sup> L1	<sup>3)</sup> L2	<sup>2)</sup> L3	M	D	SW-A	SW-B	C	d		
0	~ 22.5	8	18.5	9x0.5	14.5	11.0	11.0	3.0	10.0		Ø 10.1
1	~ 27	13	22.5	14x1	18.0	17.0	14.0	3.0	14.0		Ø 14.1
2	~ 29.5	9	23.0	16x1	22.0	19.0	17.0	4.0	16.0		Ø 16.1
3	~ 32	12	26.5	20x1	26.0	25.0	24.0	4.0	20.0		Ø 20.1

<sup>3)</sup> min. wallthickness without using a distance ring.

**G 4** **Style 4** – ODU MINI-SNAP WATERTIGHT RECEPTACLE IP 68\*, installation from front of panel with low rear profile

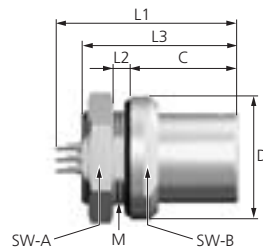

Technical Data

- IP 68 in reference to the end device and in unmated condition
- Anti-rotation feature
- contact configuration and PCB-Layout from page 73
- No crimp contacts possible

Size	Dimensions in mm										Panel Cut-Out
	<sup>1)</sup> L1	L2	<sup>2)</sup> L3	M	D	SW-A	SW-B	C	SW		
0	~ 22.5	~ 4	18.5	9x0.5	14.5	11.0	12.0	12.0	SW	8.3 / Ø 9.1	
1	~ 27	~ 4	22.5	14x1	18.0	17.0	14.0	15.5	SW	12.1 / Ø 14.1	
2	~ 29.5	~ 4.5	23.0	16x1	21.0	19.0	17.0	15.5	SW	13.6 / Ø 16.1	
3	~ 32	~ 6	26.5	18x1	24.0	22.0	20.0	16.0	SW	16.6 / Ø 18.1	

\*Reference: Potted Receptacle please see page 123 III

### Part number key

1	2	3	4	5	6	7	8	9	10	11	12	13	14	15	16	17	18	19
			B			-								-				

<sup>1)</sup> L1 = Maximum Length incl. Contact Insert  
<sup>2)</sup> L3 = Length of Housing

## Receptacle

**G 8**

**Style 8** – ODU MINI-SNAP **WATERTIGHT RECEPTACLE IP 68\***, with slotted nut, installation from rear of panel

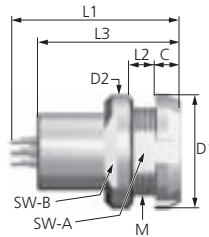

### Technical Data

- IP 68 in reference to the end device and in mated condition
- Anti-rotation feature
- contact configuration and PCB-Layout from page 73
- nutdriver for slotted mounting nut, Page 111
- no crimp contacts possible

Size	Dimensions in mm									 Panel Cut-Out
	<sup>1)</sup> L1	L2	<sup>2)</sup> L3	M	D1	D2	C	SW-A	SW-B	
0	~ 22.5	~ 3.5	18.5	10x0.5	15.0	14.5	3.0	9	12	SW 9.1 / Ø 10.1
1	~ 27	~ 4.0	22.5	14x1	18.0	18.0	4.0	12	14	SW 12.1 / Ø 14.1
2	~ 29.5	~ 3.0	23.0	16x1	22.0	21.0	5.0	15	18	SW 15.1 / Ø 16.1
3	~ 32	~ 6.0	26.5	20x1	25.0	26.0	5.0	18	-	SW 18.1 / Ø 20.1

\*Reference: Potted Receptacle please see page 123 III.

Part number key

1	2	3	4	5	6	7	8	9	10	11	12	13	14	15	16	17	18	19
				B			-							-				

<sup>1)</sup> L1 = Maximum Length incl. Contact Insert  
<sup>2)</sup> L3 = Length of Housing

**Receptacle**

**G D**

**Style D** – ODU MINI-SNAP RECEPTACLE IP 68\*, with round nut, installation from rear of panel

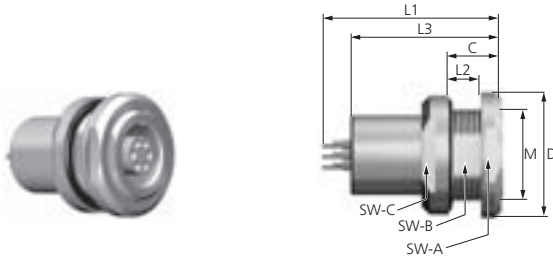

Technical Data

- IP 68 in reference to the end device and in mated condition
- Anti-rotation feature
- contact configuration and PCB-Layout from page 73
- no crimp contacts possible

Size	Dimensions in mm									 Panel Cut-Out
	<sup>1)</sup> L1	L2	<sup>2)</sup> L3	M	D	SW-A	SW-B	SW-C	C	
0	~ 22.5	~ 4.0	18.5	10x0.5	14.5	12	9	12	6.5	SW 9.1 / Ø 10.1
1	~ 27	~ 5.0	22.5	14x1	19.0	17	12	14	8.0	SW 12.1 / Ø 14.1
2	~ 29.5	~ 5.0	23.0	16x1	21.8	19	15	18	8.0	SW 15.1 / Ø 16.1
3	~ 32	~ 7.0	26.5	20x1	26.9	24	18	-	11.0	SW 18.1 / Ø 20.1

**G E**

**Style E** – ODU MINI-SNAP RECEPTACLE IP 68\*, installation from front of panel

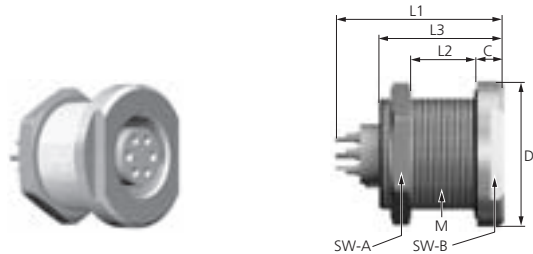

Technical Data

- IP 68 in mated condition
- contact configuration and PCB-Layout from page 73

Size	Dimensions in mm								 Panel Cut-Out
	<sup>1)</sup> L1	L2	<sup>2)</sup> L3	M	D	SW-A	SW-B	C	
0	~ 20	~ 8	14.5	11x0.75	15.5	13	12	3	Ø 11.1
1	~ 24	~ 10	16.5	14x1	18.0	17	14	3	Ø 14.1
2	~ 27	~ 11	18.5	17x1	22.0	19	17	4	Ø 17.1

\*Reference: Potted Receptacle please see page 123 III

# Details for the Part Number Key:

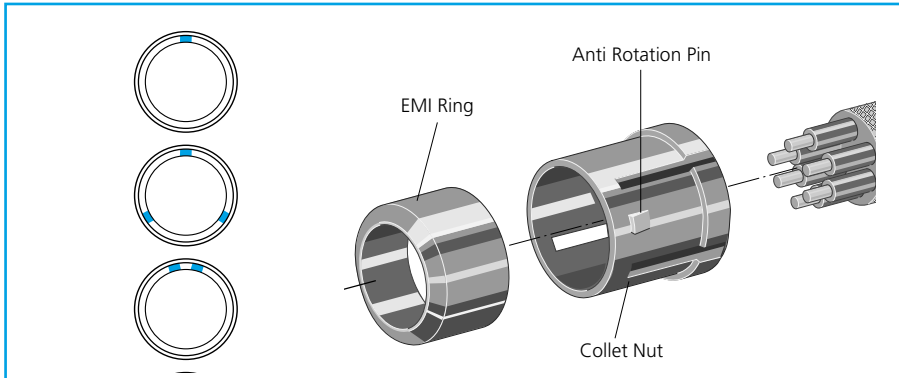

- Keying
- Housing Materials / Surfaces
- Collet System
- Bend Protection Sleeves



### Coding Series B

### Part number key

1	2	3	4	5	6	7	8	9	10	11	12	13	14	15	16	17	18	19
			<b>B</b>			-								-				

	Angle	Receptacle Front View	Size			
			0	1	2	3
<b>0</b>	0°		●	●	●	●
<b>A</b>	30°		●	●	●	●
<b>B</b>	37.5°				●	○
<b>C</b>	45°				●	●
<b>C</b>	-45°		●	●		
<b>F</b>	60°		●	●	●	●
<b>H</b>	75°				●	●
<b>J</b>	90°		●	●		●
<b>K</b>	95°				●	●
<b>M</b>	100°				○	●
<b>Q</b>	120°			●	●	○
<b>T</b>	125°					●
<b>V</b>	135°		○	●		●
<b>W</b>	145°		○	○	●	○
<b>Y</b>	155°		●	●		

● Standard  
○ On request

## Housing Materials / Surfaces

### Part number key

1	2	3	4	5	6	7	8	9	10	11	12	13	14	15	16	17	18	19
			B			-								-				



**C**

**Standard**

Cu-alloy / matt chromate

**Special materials and surfaces on request.**

**N**

Cu-alloy / nickel

**S**

Cu-alloy / black chromate

## Collet System

### Part number key

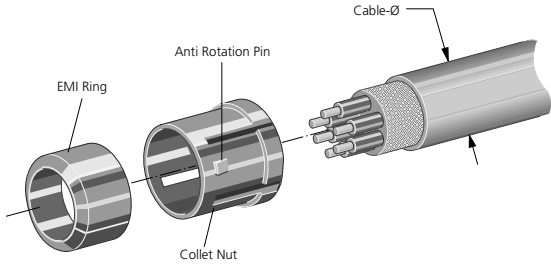

1	2	3	4	5	6	7	8	9	10	11	12	13	14	15	16	17	18	19
			<b>B</b>			<b>-</b>								<b>-</b>				

**Insert:** for all Plugs and In-Line Receptacles.

**Application:** **Collet nut** for strain relief,  
**EMI ring** for conductive path between shield and housing.

**References:**

- 1 This application is not available for applications with cable bend relief

Cable diameter in mm	Size			
	0	1	2	3
> 1.0 – 1.5		●		
> 1.5 – 2.0	●	●		
> 2.0 – 2.5	●	●	●	
> 2.5 – 3.0	●	●	●	
> 3.0 – 3.5	●	●	●	●
> 3.5 – 4.0	●	●	●	●
> 4.0 – 4.5	●	●	●	●
> 4.5 – 5.0	●	●	●	●
> 5.0 – 5.5		●	●	●
> 5.5 – 6.0		●	●	●
> 6.0 – 6.5		●	●	●
> 6.5 – 7.0		●	●	●
> 7.0 – 7.5			●	●
> 7.5 – 8.0			●	●
> 8.0 – 8.5			●	●
> 8.5 – 9.0			●	●
> 9.0 – 9.5				●
> 9.5 – 10.0				●
> 10.0 – 10.5				●
> 10.5 – 11.5				
without collet system				



### Right-Angled Print Contacts in the Receptacle

#### Part number key

1	2	3	4	5	6	7	8	9	10	11	12	13	14	15	16	17	18	19
			B			-				Q		0	0	-			0	0

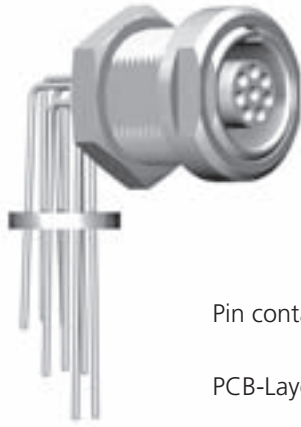

Right-Angled Print Contact

A

Pin contacts on request!

PCB-Layout see Page 84–91

### Definition of the Back Nut

(Straight-Angled-Break Apart Plugs, Inline Receptacles, Receptacles Style 6 & 7)

#### Part number key

1	2	3	4	5	6	7	8	9	10	11	12	13	14	15	16	17	18	19
			B			-								-			0	



Standard Back Nut

0

Back Nut for Silicon Cable Bend Reliefs

S

Cable Bend Reliefs on page 70

### Cable Bend Reliefs

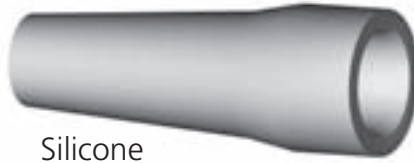

Silicone

#### Temperature range

Silicone -50 °C up to +200 °C  
short term up to +230 °C  
autoclavable

### Part number key

1	2	3	4	5	6	7	8	9	10	11	12	13	14	15	16	17	18	19
						-								-				S

### Color of the Cable Bend Relief

Color / RAL-number <small>(similar)</small>	
red	RAL 3020
white	RAL 9010
yellow	RAL 1016
green	RAL 6029
blue	RAL 5002
grey	RAL 7005
black	RAL 9005
<b>without cable bend relief</b>	



# Inserts Series L, K, B

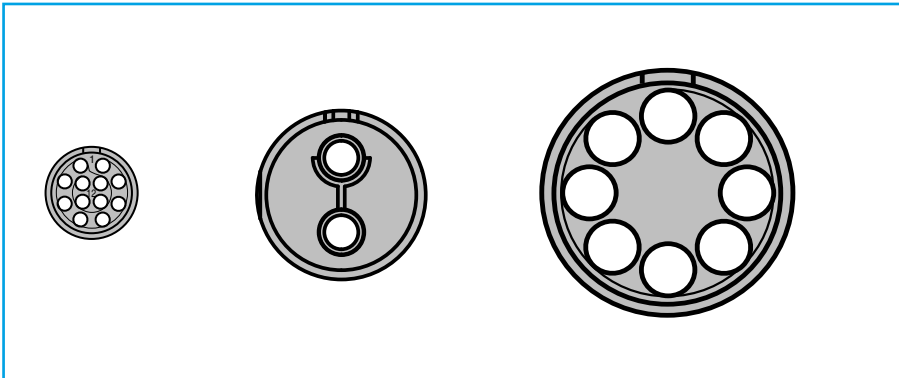

PCB and solder contacts are factory-installed in the insulation body.

Crimp contacts are shipped separately



## Insulation Body Material

### Part number key

1	2	3	4	5	6	7	8	9	10	11	12	13	14	15	16	17	18	19
						-								-			0	



**P**

PEEK

**T**

PBT (from size 2 available)

**Further materials on request**

### Turned Contacts

Article Number	PBT	PEEK
Solder Termination	●	●
Crimp Termination	●	●
PCB Termination	●	●

● = available

# Size 00

## Part number key

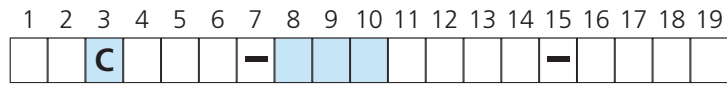

Standard Contact Configuration	Size	Material insulating body Positions	Material insulating body Positions	Material insulating body Positions	Contact Ø mm	Nominal Signal Contact Current Load in A (Derating factor see page 130)	Series		Clearance and creepage distance		Test Voltage acc. SAE AS13441:1998 method 3001.1 (kVeff)	Nominal Voltage acc. SAE AS13441:1998 method 3001.1 (kVrms) <sup>1)</sup>	Termination			View on termination side	
							L	B	L	B			Solder	Crimp (Tools for assembling see page 110)	Print (PCB Layout see page 84)	Pin Part	Socket
C	C	P	0	2	0.5	5	L 0.6 B N/A K N/A	L 0.8 B N/A K N/A	1.100	0.366	●	●					
C	C	P	0	3	0.5	5	L 0.5 B N/A K N/A	L 0.7 B N/A K N/A	1.100	0.366	●	●					
C	C	P	0	4	0.5	5	L 0.4 B N/A K N/A	L 0.6 B N/A K N/A	0.900	0.300	●	●					

**Attention:** Inserts in Size 00 are only in PEEK available.

Inserts Series L, K, B

1) Nominal Voltage acc. SAE AS 13441:1998 method 3001.1 meet the MIL-STD 1344, method 3001, Test acc. IEC 60512 test 4a. Method of calculation, utilization warning and Proposals see page 124

# Size 0

## Part number key

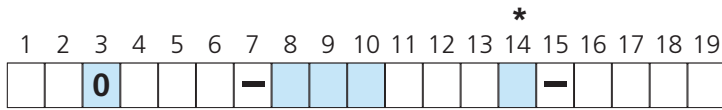

	Size	Material insulating body	Positions	Positions	Contact Ø mm	Nominal Signal Contact Current Load in A (Derating factor see page 130)	Series		Clearance and creepage distance		Test Voltage acc. SAE AS13441:1998 method 3001.1 (kVeff)	Nominal Voltage acc. SAE AS13441:1998 method 3001.1 (kVrms) <sup>1)</sup>	Termination			View on termination side	
							Series	Contact to contact in mm	Series	Contact to housing in mm			Solder	Crimp (Tools for assembling see page 110)	Print (PCB Layout see page 85 - 86)	Pin Part	Socket
Standard Contact Configuration	0		P	0	2	0.9	10	L 1.0 B 1.0 K 1.0	L 1.0 B 1.0 K 0.9	1.500	0.500	●	●	●			
	0		P	0	3	0.9	10	L 0.8 B 0.8 K 0.8	L 1.0 B 1.0 K 0.8	1.200	0.400	●	●	●			
	0		P	0	4	0.7	7	L 0.8 B 0.8 K 0.8	L 1.0 B 1.0 K 0.8	0.900	0.300	●	●	●			
	0		P	0	5	0.7	7	L 0.7 B 0.7 K 0.7	L 0.8 B 0.8 K 0.7	1.100	0.366	●	●	●			
	0		P	0	6	0.5	5	L 0.9 B 0.9 K 0.9	L 0.8 B 0.8 K 0.7	0.900	0.300	●		●			
	0		P	0	7	0.5	5	L 0.7 B 0.7 K 0.7	L 0.8 B 0.8 K 0.7	0.900	0.300	●		●			
	0		P	0	9	0.5	5	L 0.4 B 0.4 K 0.4	L 0.8 B 0.8 K 0.7	0.600	0.200	●		●			
	0		*	P	1	0	0.5	5	L 0.3 B 0.3 K 0.3	L 0.7 B 0.7 K 0.5	0.600	0.200	●				

**Attention:** Inserts in Size 0 are only in PEEK available.

\* Not compatible to the competitors. Position 14 of order number = 9

1) Nominal Voltage acc. SAE AS 13441:1998 method 3001.1 meet the MIL-STD 1344, method 3001, Test acc. IEC 60512 test 4a. Method of calculation, utilization warning and Proposals see page 124.



## Size 2

### Part number key

1	2	3	4	5	6	7	8	9	10	11	12	13	14	15	16	17	18	19
	2					-								-				

Standard Contact Configuration	Size	Material Isolierkörper	Positions	Positions	Contact Ø mm	Nominal Signal Contact Current Load in A (Derating factor see page 130)	Series		Clearance and creepage distance	Test Voltage acc. SAE AS13441:1998 method 3001.1 (kVeff)	Nominal Voltage acc. SAE AS13441:1998 method 3001.1 (kVrms) <sup>1)</sup>	Termination			View on termination side	
							Contact to contact in mm	Contact to housing in mm				Solder	Crimp (Tools for assembling see page 110)	Print (PCB Layout see page 89)	Pin part	Socket
2	PEEK	P	0	2	2.0	22	L 2.0	L 1.6	2.100	0.700	●	●	●			
							B 2.0	B 1.4								
2	PBT	T	0	3	1.6	17	L 1.9	L 1.7	2.400	0.800	●	●	●			
							B 1.9	B 1.6								
2	PEEK	P	0	4	1.3	14	L 2.0	L 1.8	1.950	0.650	●	●	●			
							B 2.0	B 1.6								
2	PBT	T	0	5	1.3	14	L 1.6	L 1.7	1.800	0.600	●	●	●			
							B 1.6	B 1.5								
2	PEEK	P	0	6	1.3	14	L 1.3	L 1.5	1.500	0.500	●	●	●			
							B 1.3	B 1.3								
2	PBT	T	0	7	1.3	14	L 1.3	L 1.4	1.800	0.600	●	●	●			
							B 1.3	B 1.2								
2	PEEK	P	0	8	0.9	10	L 1.3	L 1.2	1.500	0.500	●	●	●			
							B 1.3	B 1.1								
2	PBT	T	0	10	0.9	10	L 1.0	L 1.2	1.500	0.500	●	●	●			
							B 1.0	B 1.1								
2	PEEK	P	1	2	0.7	7	L 1.0	L 1.3	1.350	0.450	●	●	●			
							B 1.0	B 1.1								
2	PBT	T	1	2	0.7	7	L 1.0	L 1.0	1.350	0.450	●	●	●			
							B 1.0	B 1.0								

Continue next page

1) Nominal Voltage acc. SAE AS 13441:1998 method 3001.1 meet the MIL-STD 1344, method 3001, Test acc. IEC 60512 test 4a.  
Method of calculation, utilization warning and Proposals see page 124

## Size 2 (Continue)

### Part number key

1	2	3	4	5	6	7	8	9	10	11	12	13	14	15	16	17	18	19
	2					-								-				

	Size	Material insulating body	Positions	Positions	Contact Ø mm	Nominal Signal Contact Current Load in A (Derating factor see page 130)	Series	Clearance and creepage distance		Test Voltage acc. SAE AS13441:1998 method 3001.1 (kVeff)	Nominal Voltage acc. SAE AS13441:1998 method 3001.1 (kVrms) <sup>1)</sup>	Termination			View on termination side			
								Series	Contact to contact in mm			Series	Contact to housing in mm	Solder	Crimp (Tools for assembling see page 110)	Print (PCB Layout see page 89)	Pin part	Socket
Standard Contact Configuration	2	PEEK	P	1	4	0.7	7	L	0.9	L	1.2	1.200	0.400	●	●	●		
		PBT						T	B	0.9	B							
	2	PEEK	P	1	6	0.7	7	L	0.8	L	1.2	1.100	0.366	●	●	●		
		PBT						T	B	0.8	B							
	2	PEEK	P	1	8	0.7	7	L	0.7	L	1.2	0.900	0.300	●	●	●		
PBT		T						B	0.7	B	1.1							
2	PEEK	P	1	9	0.7	7	L	0.7	L	1.2	1.000	0.333	●	●	●			
	PBT						T	B	0.7	B								1.1
2	PEEK	P	2	6	0.5	5	L	0.6	L	1.1	0.900	0.300	●	●				
	PBT						T	B	0.6	B								1.0

Inserts Series L, K, B

1) Nominal Voltage acc. SAE AS 13441:1998 method 3001.1 meet the MIL-STD 1344, method 3001, Test acc. IEC 60512 test 4a. Method of calculation, utilization warning and Proposals see page 124



### Size 3 (Continue)

#### Part number key

1	2	3	4	5	6	7	8	9	10	11	12	13	14	15	16	17	18	19
		3				-								-				

Size	Material insulating body	Positions	Positions	Contact Ø mm	Nominal Signal Contact Current Load in A (Derating Factor see page 130)	Series	Clearance and creepage distance		Test Voltage acc. SAE AS13441:1998 method 3001.1 (kVeff)	Nominal Voltage acc. SAE AS13441:1998 method 3001.1 (kVrms) <sup>1)</sup>	Termination			View on termination side		
							Contact to contact in mm	Series			Contact to housing in mm	Solder	Crimp (Tools for assembling see page 110)	Print (PCB Layout see page 90)	Pin part	Socket
3	PEEK PBT	P T	3 0	0.7	7	L B K	0.6 0.6 0.6	L B K	1.2 1.2 0.9	0.900	0.300	● ● ●	● ● ●	● ● ●		

### Size 4

#### Part number key

1	2	3	4	5	6	7	8	9	10	11	12	13	14	15	16	17	18	19
		4				-								-				

Size	Material insulating body	Positions	Positions	Contact Ø mm	Nominal Signal Contact Current Load in A (Derating Factor see page 130)	Series	Clearance and creepage distance		Test Voltage acc. SAE AS13441:1998 method 3001.1 (kVeff)	Nominal Voltage acc. SAE AS13441:1998 method 3001.1 (kVrms) <sup>1)</sup>	Termination			View on termination side		
							Contact to contact in mm	Series			Contact to housing in mm	Solder	Crimp (Tools for assembling see page 110)	Print (PCB Layout see page 91)	Pin part	Socket
4	PEEK PBT	P T	0 7	2.0	22	L B K	2.1 2.1 2.1	L B K	2.2 N/A 1.6	1.650	0.550	● ● ●	● ● ●	● ● ●		
4	PEEK PBT	P T	3 0	0.9	10	L B K	0.8 0.8 0.8	L B K	1.7 N/A 1.0	1.575	0.520	● ● ●	● ● ●	● ● ●		
4	PEEK PBT	P T	4 0	0.7	7	L B K	0.8 0.8 0.8	L B K	1.7 N/A 1.0	1.000	0.333	● ● ●	● ● ●	● ● ●		

1) Nominal Voltage acc. SAE AS 13441:1998 method 3001.1 meet the MIL-STD 1344, method 3001, Test acc. IEC 60512 test 4a.  
Method of calculation, utilization warning and Proposals see page 124

## Size 5

### Part number key

1	2	3	4	5	6	7	8	9	10	11	12	13	14	15	16	17	18	19	
		5				-									-				

Size	Material insulating body	Positions	Positions	Contact Ø mm	Nominal Signal Contact Current Load in A (Derating factor see page 122)	Clearance and creepage distance	Termination	View on termination side	
								Pin part	Socket
5	PEEK PBT	P T	2 5	20 x 0.9 4 x 3.0 1 x 50 Ω Koax	Special insert: Electrical Datas on Request		Solder Crimp Print		

## Size 6

### Part number key

1	2	3	4	5	6	7	8	9	10	11	12	13	14	15	16	17	18	19	
		6				-									-				

Standard Contact Configuration	Size	Material insulating body	Positions	Positions	Contact Ø mm	Nominal Signal Contact Current Load in A (Derating Factor see page 122)	Clearance and creepage distance	Termination	View on termination side	
									Pin part	Socket
	6	PEEK PBT	P T	0 2	2 x 4.0	Special insert: Electrical Datas on Request		Solder Crimp Print		
	6	PEEK PBT	P T	0 5	5 x 75 Ω Koax	Special insert: Electrical Datas on Request		Solder Crimp Print		
6	PEEK PBT	P T	2 2	14 x 0.9 3 x 1.6 3 x 2.5 2 x 75 Ω Koax	Special insert: Electrical Datas on Request		Solder Crimp Print			

### Contact Type / Contact Surface

#### Part number key

1	2	3	4	5	6	7	8	9	10	11	12	13	14	15	16	17	18	19
						-									-			

	Type	Surface	
Solder	Socket	0.75 µm Au (min.)	L
	Pin	0.75 µm Au (min.)	M
Crimp	Socket	0.75 µm Au (min.)	N
	Pin	0.75 µm Au (min.)	P
Print	Socket	0.75 µm Au (min.)	Q
	Pin	0.75 µm Au (min.)	R



### Contact Termination Cross Sections

#### Part number key

1	2	3	4	5	6	7	8	9	10	11	12	13	14	15	16	17	18	19
						-								-			0	0

#### Crimp Contact

Size	Pos.	Contact Ø (mm)	AWG	mm <sup>2</sup>	
0	4-5	0.7	28-32	0.09-0.04	<b>F C O</b>
			22-26	0.38-0.15	<b>F G O</b>
	2-3	0.9	22-26	0.38-0.15	<b>J G O</b>
			20-24	0.50-0.25	<b>J H O</b>
1	6-8	0.7	28-32	0.09-0.04	<b>F C O</b>
			22-26	0.38-0.15	<b>F G O</b>
	4-5	0.9	22-26	0.38-0.15	<b>J G O</b>
			20-24	0.50-0.25	<b>J H O</b>
2-3	1.3	18-20	1.0-0.5	<b>P L O</b>	
2	12-19	0.7	28-32	0.09-0.04	<b>F C O</b>
			22-26	0.38-0.15	<b>F G O</b>
	8-10	0.9	22-26	0.38-0.15	<b>J G O</b>
			20-24	0.50-0.25	<b>J H O</b>
4-7	1.3	18-20	1.0-0.5	<b>P L O</b>	
3	20-30	0.7	28-32	0.09-0.04	<b>F C O</b>
			22-26	0.38-0.15	<b>F G O</b>
	14-18	0.9	22-26	0.38-0.15	<b>J G O</b>
			20-24	0.50-0.25	<b>J H O</b>
	8-10	1.3	18-20	1.0-0.5	<b>P L O</b>
	7	1.6	18-20	1.0-0.5	<b>S L O</b>
14-18			1.5-1.0	<b>S N O</b>	



Tools for crimping and their adjustments  
see page 108 to 110

### Contact Termination Cross Sections

#### Part number key

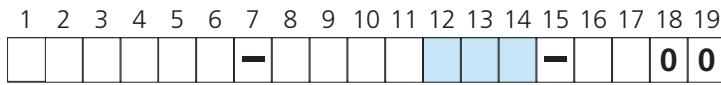

#### Solder Contact

Contact Ø	Term. Ø	Term. Cross	
		AWG	mm <sup>2</sup>
0.5	0.4	28	0.08
0.7	0.6	26	0.15
0.7	0.85	22	0.38
0.9	0.85	22	0.38
1.3	1.1	20	0.50
1.6	1.4	18	1.00
2.0	1.85	14	1.5
2.0	2.4	12	2.5



C	C	0
F	D	0
F	G	0
J	G	0
P	H	0
S	N	0
T	Q	0
T	S	0

#### PCB Contact

Contact Ø	Term. Ø
0.5	0.5
0.7	0.5
0.9	0.7
1.3	0.7
1.6	0.7
2.0	0.7

C	0	0
F	0	0
J	0	0
P	0	0
S	0	0
T	0	0

**For mixed inserts**

0	0
---	---





(Please provide details of termination cross section!)

Size 00 – PCB-Layout for print-contacts

	Straight	90° right-angled	without thread
Positions			
2	Drill: 0.6 mm 	Drill: 0.6 mm 	Drill-contact: 0.6 mm Drill-mounting: 0.8 mm 
3	Drill: 0.6 mm 	Drill: 0.6 mm 	Drill-contact: 0.6 mm Drill-mounting: 0.8 mm 
4	Drill: 0.6 mm 	Drill: 0.6 mm 	Drill-contact: 0.6 mm Drill-mounting: 0.8 mm 

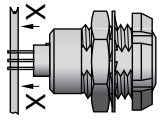
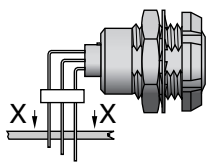
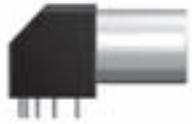
The showed layouts are only considered with sockets in the receptacle.

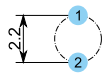
**Size 0 – PCB-Layout for print-contacts**

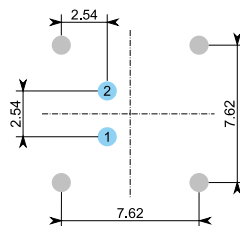
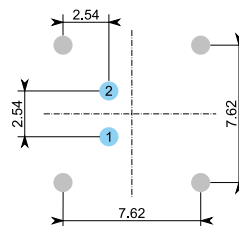
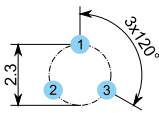
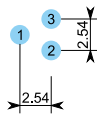
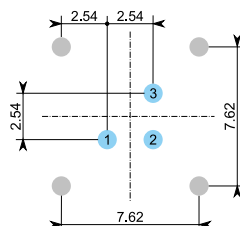
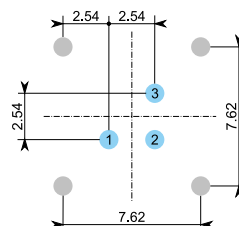
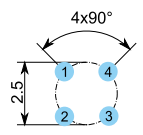
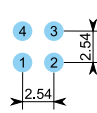
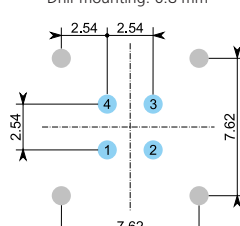
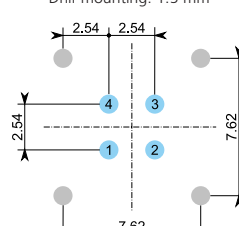
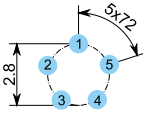
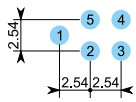
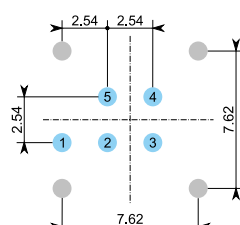
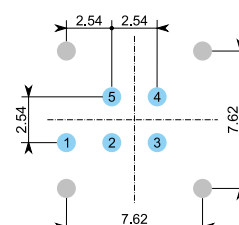
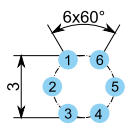
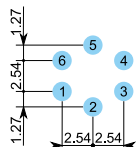
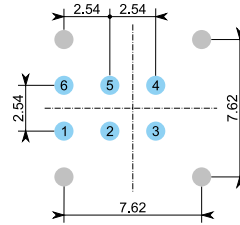
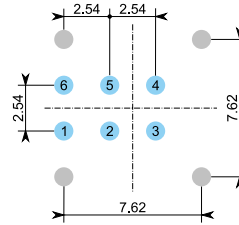
Positions	Straight	90° right-angled	without thread	with thread
				
2	Drill: 0.8 mm 	Drill: 0.7 mm 	Drill-contact: 0.8 mm Drill-mounting: 0.8 mm 	Drill-contact: 0.8 mm Drill-mounting: 1.5 mm 
3	Drill: 0.8 mm 	Drill: 0.7 mm 	Drill-contact: 0.8 mm Drill-mounting: 0.8 mm 	Drill-contact: 0.8 mm Drill-mounting: 1.5 mm 
4	Drill: 0.6 mm 	Drill: 0.7 mm 	Drill-contact: 0.8 mm Drill-mounting: 0.8 mm 	Drill-contact: 0.8 mm Drill-mounting: 1.5 mm 
5	Drill: 0.6 mm 	Drill: 0.7 mm 	Drill-contact: 0.8 mm Drill-mounting: 0.8 mm 	Drill-contact: 0.8 mm Drill-mounting: 1.5 mm 
6	Drill: 0.6 mm 	Drill: 0.7 mm 	Drill-contact: 0.8 mm Drill-mounting: 0.8 mm 	Drill-contact: 0.8 mm Drill-mounting: 1.5 mm 

Inserts Series L, K, B





The showed layouts are only considered with sockets in the receptacle.

Size 0 – PCB-Layout for print-contacts

	Straight	90° right-angled	without thread	with thread
Positions				
7	Drill: 0.6 mm 	Drill: 0.7 mm 	Drill-contact: 0.8 mm Drill-mounting: 0.8 mm 	Drill-contact: 0.8 mm Drill-mounting: 1.5 mm 
9	Drill: 0.6 mm 	Drill: 0.6 mm 		

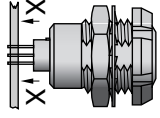
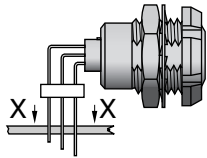
The showed layouts are only considered with sockets in the receptacle.

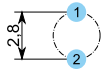
Size 1 – PCB-Layout for print-contacts

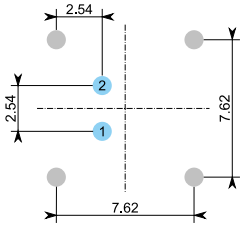
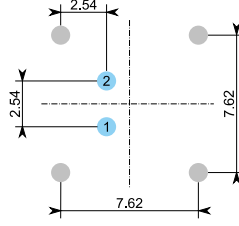
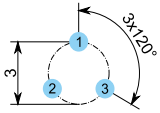
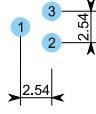
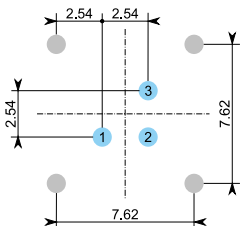
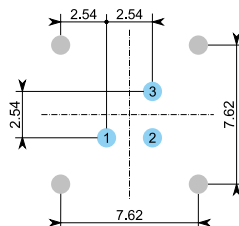
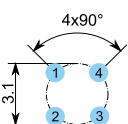
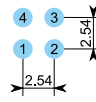
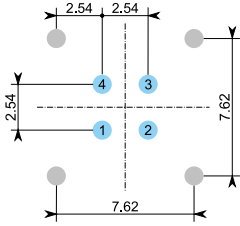
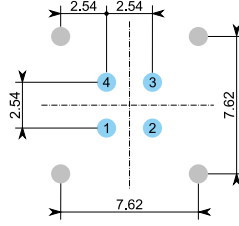
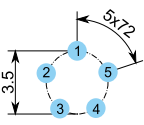
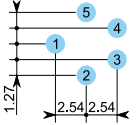
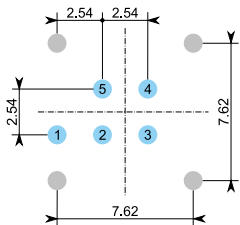
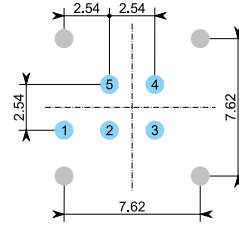
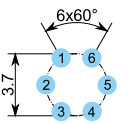
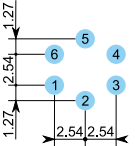
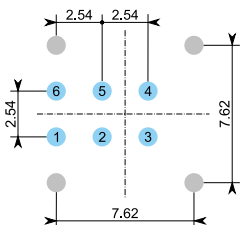
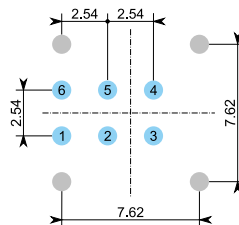
Positions	Straight	90° right-angled	without thread	with thread
				
2	Drill: 0.8 mm 	Drill: 0.9 mm 	Drill-contact: 0.8 mm Drill-mounting: 0.8 mm 	Drill-contact: 0.8 mm Drill-mounting: 1.5 mm 
3	Drill: 0.8 mm 	Drill: 0.9 mm 	Drill-contact: 0.8 mm Drill-mounting: 0.8 mm 	Drill-contact: 0.8 mm Drill-mounting: 1.5 mm 
4	Drill: 0.6 mm 	Drill: 0.7 mm 	Drill-contact: 0.8 mm Drill-mounting: 0.8 mm 	Drill-contact: 0.8 mm Drill-mounting: 1.5 mm 
5	Drill: 0.8 mm 	Drill: 0.7 mm 	Drill-contact: 0.8 mm Drill-mounting: 0.8 mm 	Drill-contact: 0.8 mm Drill-mounting: 1.5 mm 
6	Drill: 0.6 mm 	Drill: 0.7 mm 	Drill-contact: 0.8 mm Drill-mounting: 0.8 mm 	Drill-contact: 0.8 mm Drill-mounting: 1.5 mm 

The showed layouts are only considered with sockets in the receptacle.

Size 1 – PCB-Layout for print-contacts

	Straight	90° right-angled	without thread	with thread
Positions				
7	Drill: 0.6 mm 	Drill: 0.7 mm 	Drill-contact: 0.8 mm Drill-mounting: 0.8 mm 	Drill-contact: 0.8 mm Drill-mounting: 1.5 mm 
8	Drill: 0.6 mm 	Drill: 0.7 mm 	Drill-contact: 0.8 mm Drill-mounting: 0.8 mm 	Drill-contact: 0.8 mm Drill-mounting: 1.5 mm 
10	Drill: 0.6 mm 	Drill: 0.7 mm 	Drill-contact: 0.8 mm Drill-mounting: 0.8 mm 	Drill-contact: 0.8 mm Drill-mounting: 1.5 mm 
14	Drill: 0.6 mm 	Drill: 0.7 mm 		

The showed layouts are only considered with sockets in the receptacle.

Size 2 – PCB-Layout for print-contacts

Size 2 – PCB-Layout for print-contacts

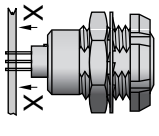
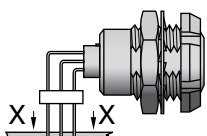
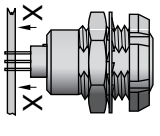
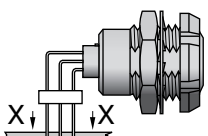
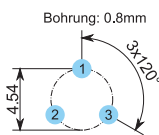
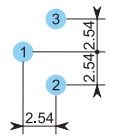
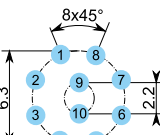
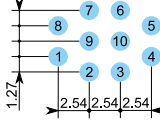
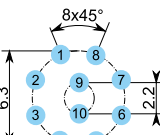
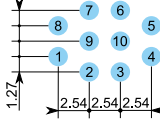
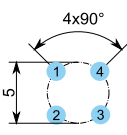
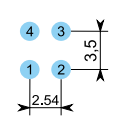
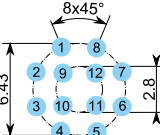
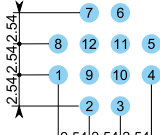
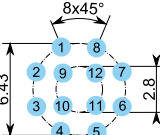
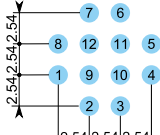
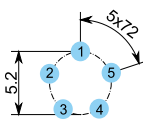
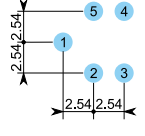
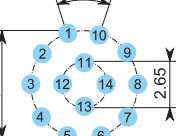
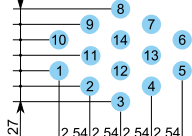
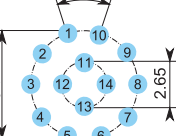
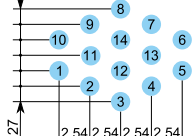
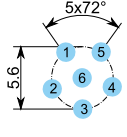
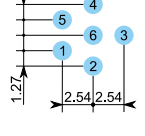
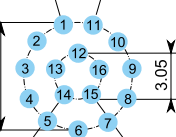
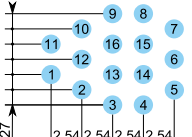
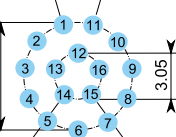
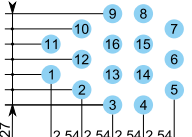
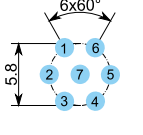
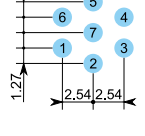
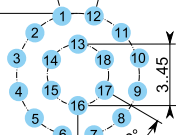
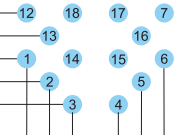
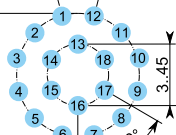
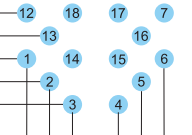
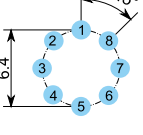
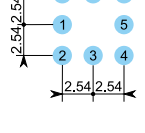
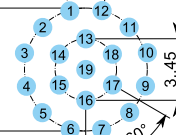
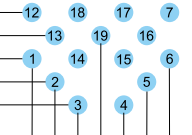
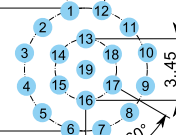
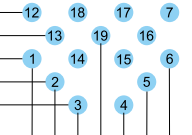
Positions	Straight		90° right-angled		Positions	Straight		90° right-angled	
									
3	Drill: 0.8 mm 	Drill: 0.9 mm 	Drill: 0.8 mm 	Drill: 0.7 mm 	10	Drill: 0.6 mm 	Drill: 0.7 mm 		
4	Drill: 0.8 mm 	Drill: 0.9 mm 	Drill: 0.6 mm 	Drill: 0.7 mm 	12	Drill: 0.6 mm 	Drill: 0.7 mm 		
5	Drill: 0.8 mm 	Drill: 0.9 mm 	Drill: 0.6 mm 	Drill: 0.7 mm 	14	Drill: 0.6 mm 	Drill: 0.7 mm 		
6	Drill: 0.8 mm 	Drill: 0.9 mm 	Drill: 0.6 mm 	Drill: 0.7 mm 	16	Drill: 0.6 mm 	Drill: 0.7 mm 		
7	Drill: 0.8 mm 	Drill: 0.7 mm 	Drill: 0.6 mm 	Drill: 0.7 mm 	18	Drill: 0.6 mm 	Drill: 0.7 mm 		
8	Drill: 0.8 mm 	Drill: 0.9 mm 	Drill: 0.6 mm 	Drill: 0.7 mm 	19	Drill: 0.6 mm 	Drill: 0.7 mm 		

The showed layouts are only considered with sockets in the receptacle.

Size 3 – PCB-Layout for print-contacts

Size 3 – PCB-Layout for print-contacts

	Straight	90° right-angled		Straight	90° right-angled
Positions			Positions		
4	Drill: 0.8 mm 	Drill: 0.7 mm	18	Drill: 0.8 mm 	Drill: 0.7 mm 
7	Drill: 0.8 mm 	Drill: 0.9 mm 	20	Drill: 0.6 mm 	Drill: 0.7 mm 
8	Drill: 0.8 mm 	Drill: 0.9 mm 	22	Drill: 0.6 mm 	
10	Drill: 0.8 mm 	Drill: 0.9 mm 	26	Drill: 0.6 mm 	Drill: 0.7 mm 
14	Drill: 0.8 mm 	Drill: 0.7 mm 	30	Drill: 0.6 mm 	Drill: 0.7 mm 
16	Drill: 0.8 mm 	Drill: 0.7 mm 			

The showed layouts are only considered with sockets in the receptacle.

**Size 4 – PCB-Layout for print-contacts**

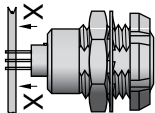
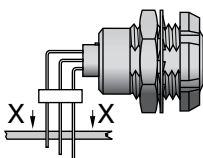
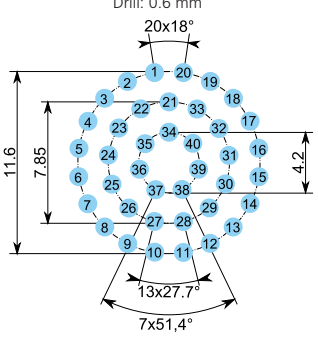
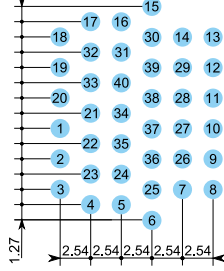
	Straight	90° right-angled
Positions		
40	<p>Drill: 0.6 mm 20x18°</p> 	<p>Drill: 0.7 mm</p> 

The showed layouts are only considered with sockets in the receptacle.



# Special Solutions



## Customer specific solutions for ODU MINI-SNAP

ODU as a specialist for customized solutions have all main competences under one roof.

Development, an own tool shop, stamping, molding, surface plating, manufacturing of complete assembly machines etc.

With all these possibilities we are able to offer "custom tailored" solutions for our customers.

### When do we actively pursue customer specific solutions?

First we have to study the customers requirements. In order to use existing development resources efficiently, it is necessary to concentrate on those ideas that are very likely to produce sustained earnings. And so we work very closely with you to develop exactly the product that optimally fulfills the requirements. And naturally the feasibility is analyzed in the starting phase of every development in order to make it possible to estimate the costs for a new development.

### Here are a few examples how a special solution may look like:

**Custom Specific Inserts**



**Special insulators and special assemblies for High-Voltage applications**

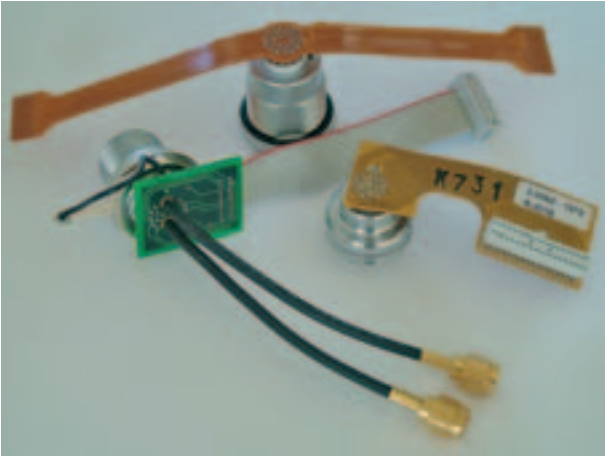

**Custom specific PCB assembling**

**Different types of surface plating**



**Special overmouldings and insulation sleeves**

**Also different locking mechanism are possible (picture: Bajonett and Threaded Locking)**





# Accessories

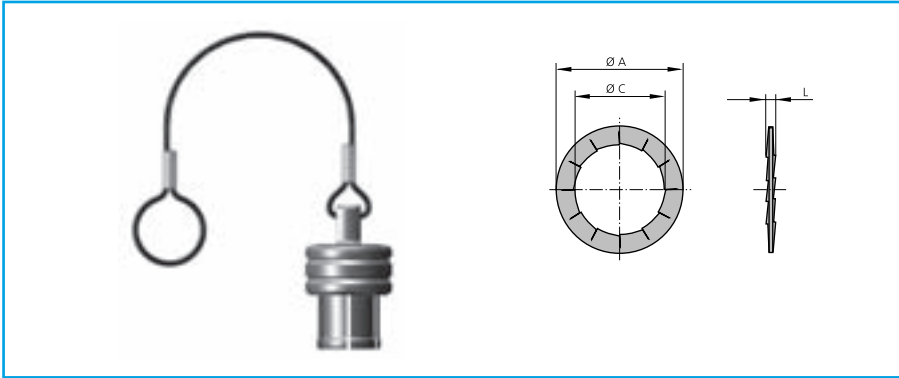

### Color Coding Ring for Series L and B

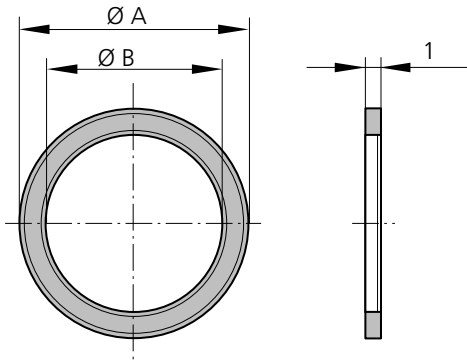

#### Mounting Example:

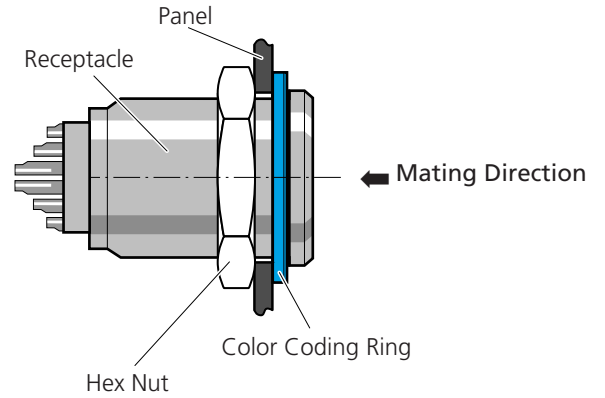

#### Order Example

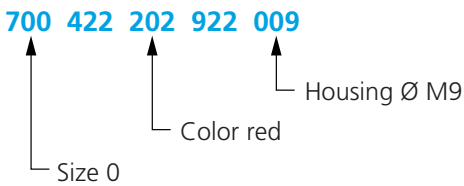

\* = In ... please indicate color code

Size	Part Number with Colour	Ø A	Ø B
00	713 422 ... 922 007	11.0	7.1
0	700 422 ... 922 009	13.5	9.1
0	700 422 ... 922 010	16.5	10.1
1	701 422 ... 922 012	17.0	12.1
1	701 422 ... 922 014	20.0	14.1
2	702 422 ... 922 015	22.0	15.1
2	702 422 ... 922 016	23.0	16.1
3	703 422 ... 922 018	25.0	18.1
3	703 422 ... 922 020	28.0	20.1

Part Number with color	Color	RAL-No. (similar)
202	red	3020
203	white	9010
204	yellow	1016
205	green	6029
206	blue	5002
207	grey	7005
208	black	9005

Because of different raw materials the colors may slightly differ from RAL numbers.

### Color Coding Ring for Series L and B

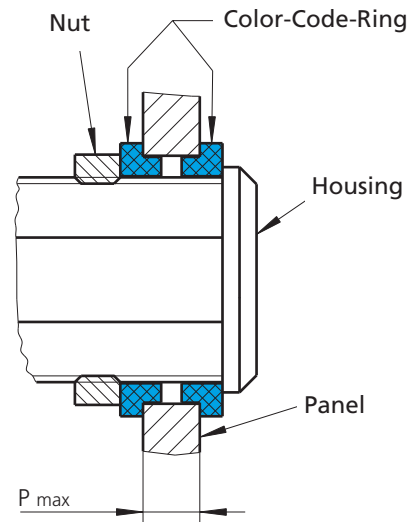
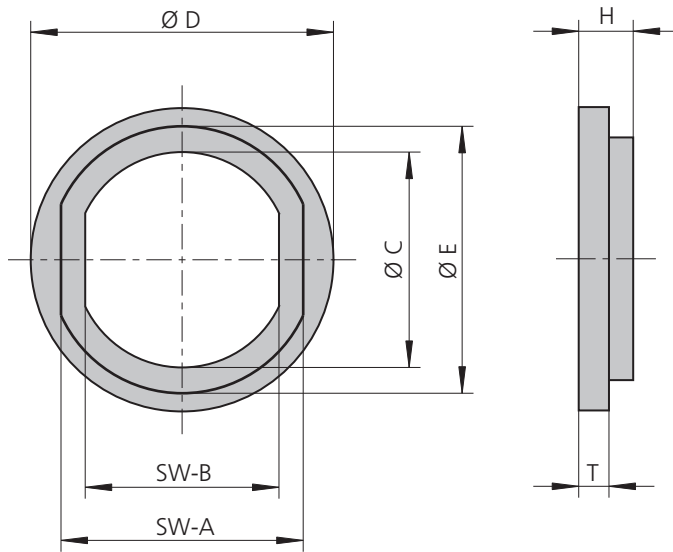

**Mounting Example:**

#### Order Example

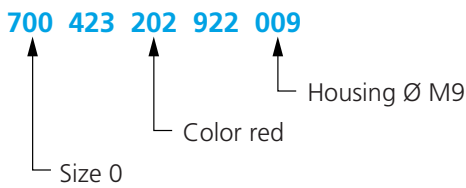

#### Size

Size	Part Number	SW-A	SW-B	Ø C	Ø D	Ø E	H	T	P max
00	713 423 ... 922 007	8.0	6.4	7.1	10.0	8.8	1.8	1.0	4.0
0 *	700 423 ... 922 009	9.9	8.3	9.1	12.0	10.8	1.8	1.0	4.0
0	700 423 ... 922 010	10.7	9.1	10.1	16.5	11.8	1.8	1.0	1.5
1 *	701 423 ... 922 012	12.2	10.6	12.1	16.0	13.8	1.8	1.0	5.0
1	701 423 ... 922 014	13.7	12.1	14.1	21.0	15.8	1.8	1.0	2.0
2 *	702 423 ... 922 015	16.2	13.6	15.1	21.0	17.8	2.2	1.2	4.6
2	702 423 ... 922 016	17.7	15.1	16.1	23.0	18.8	2.2	1.2	0.6
3 *	703 423 ... 922 018	20.2	16.6	18.2	25.0	21.8	2.2	1.2	7.6
3	703 423 ... 922 020	21.7	18.1	20.2	28.0	23.8	2.2	1.2	3.6
4 *	704 423 ... 922 025	27.2	23.7	25.2	32.0	28.8	2.5	1.5	10.0
5 *	705 423 ... 922 035	38.3	33.7	35.2	44.0	39.8	2.5	1.5	
6 *	706 423 ... 922 042	44.8	40.2	42.2	54.0	46.8	2.5	1.5	15.0

\* = In ... please indicate color code

#### Colors

	Color	RAL-No. (similar)
202	red	3020
203	white	9010
204	yellow	1016
205	green	6029
206	blue	5002
207	grey	7005
208	black	9005

Because of different raw materials the colors may slightly differ from RAL numbers.

### Hinged cover for series B, L

Suitable for all receptacle styles G1

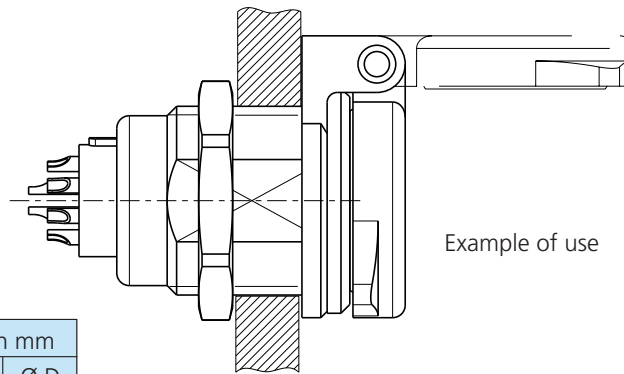
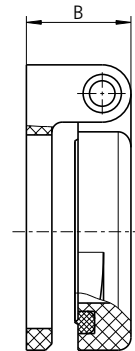
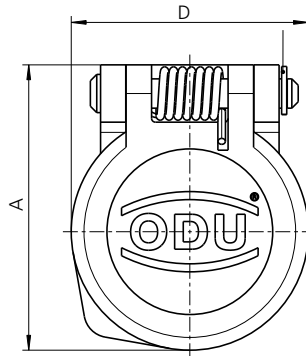

Size	Part Number	Dimensions in mm		
		A	B	Ø D
0	700 096 001 926 007	13.3	5.5	11
1	701 096 001 926 007	17.1	6.3	14.2
2	702 096 001 926 007	22.4	8.2	18.5
3	703 096 001 926 007	26.5	8.2	27.5

### Protective Covers for Receptacles (IP 50) in Series L

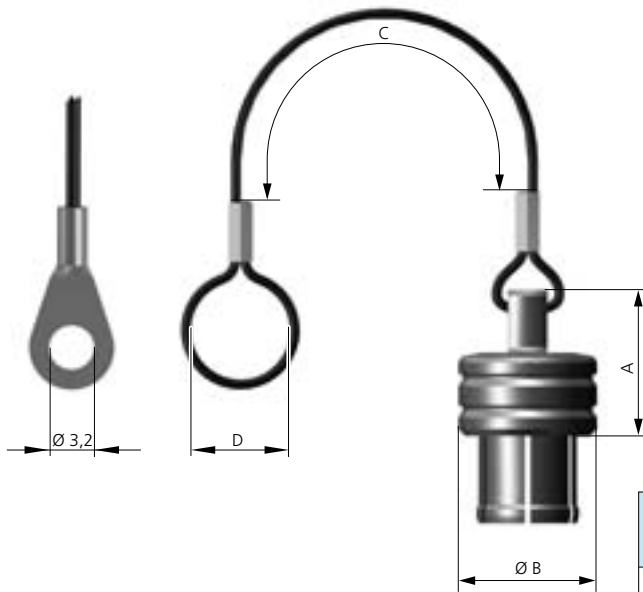

\* = With . please, register desired lanyard material  
 0 = Polyamide lanyard with loop  
 1 = Stainless steel lanyard with loop  
 2 = Polyamide lanyard solder lug  
 3 = Stainless steel lanyard solder lug  
 Surface: Matt chromate

Size	Part Number*	Dimensions in mm			
		A	B	C	D
0	700 097 003 215 .00	10.5	10	70	8
1	701 097 003 215 .00	12.5	12	75	10
2	702 097 003 215 .00	14.85	15	85	13
3	703 097 003 215 .00	16.6	18	100	16
4	704 097 003 215 00	16.9	25	110	19.5

### Protective Covers for Plugs (IP 50) in Series L

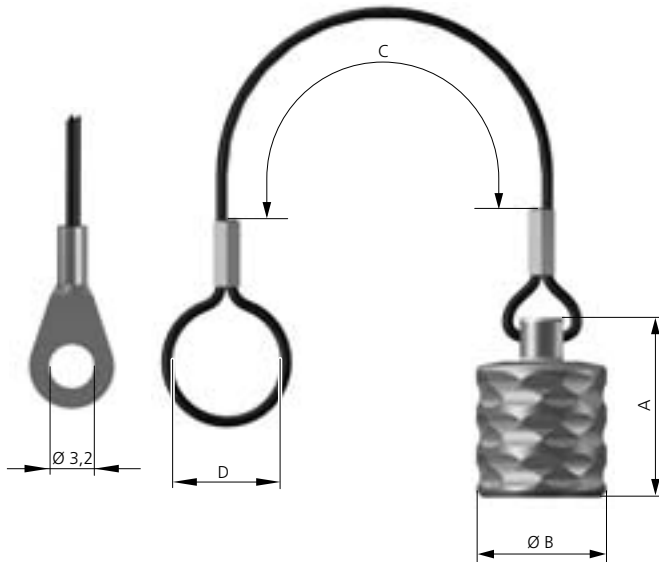

\* = With . please, register desired lanyard material  
 0 = Polyamide lanyard with loop  
 1 = Stainless steel lanyard with loop  
 2 = Polyamide lanyard solder lug  
 3 = Stainless steel lanyard solder lug  
 Surface: Matt chromate

Size	Part Number*	Dimensions in mm				Codings (see page 30)											
		A	B	C	D	0	A	B	C	F	J	K	Q	V	W	Y	
0	750 097 005 215 .0_	15	9	70	8	•	•	•	•	•						•	
1	751 097 005 215 .0_	16.5	12	75	10	•	•	•	•	•					•	•	
2	752 097 005 215 .0_	18	15	85	13	•	•	•	•			•	•		•		
3	753 097 005 215 .0_	21	18	100	15	•	•	•	•			•	•				

### Protective Covers for Receptacles (IP 68) in Series K

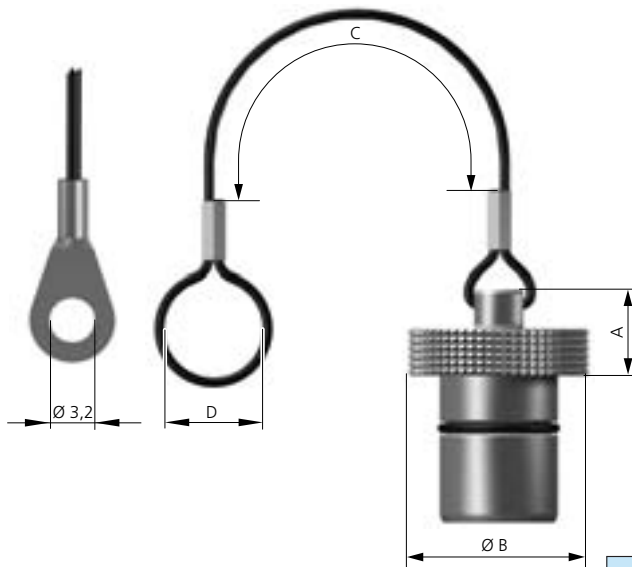

\* = With . please, register desired lanyard material  
 0 = Polyamide lanyard with loop  
 1 = Stainless steel lanyard with loop  
 2 = Polyamide lanyard solder lug  
 3 = Stainless steel lanyard solder lug  
 Surface: Matt chromate

Size	Part number*	Dimensions in mm			
		A	B	C	D
0	720 097 007 215 .00	9	15	70	6
1	721 097 007 215 .00	9	18.5	75	8
2	722 097 007 215 .00	9	21.5	85	10
3	723 097 007 215 .00	9.6	24	120	12
4	724 097 007 215 .00	11.2	31.5	140	16

### Protective Covers for Plugs (IP 68) in Series K

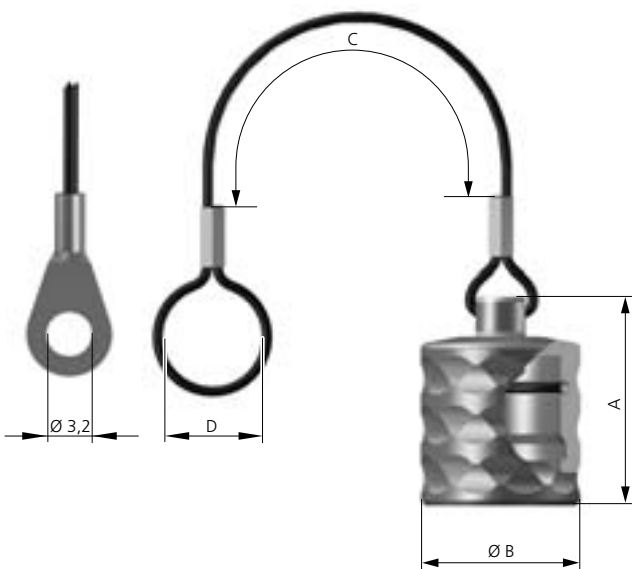

\* = With . please, register desired lanyard material  
 0 = Polyamide lanyard with loop  
 1 = Stainless steel lanyard with loop  
 2 = Polyamide lanyard solder lug  
 3 = Stainless steel lanyard solder lug  
 = With \_please register desired coding (standard = 0)

Size	Part number*	Dimensions in mm				Codings (see page 50)							
		A	B	C	D	0	A	C	F	H	K	Q	W
0	720 097 004 215 .0_	16	14	70	6	•	•	•	•				
1	721 097 004 215 .0_	21	16	75	8	•	•	•	•				
2	722 097 004 215 .0_	21.5	20	85	10	•	•	•	•				
3	723 097 004 215 .0_	25.5	24	120	12	•	•	•	•				
4	724 097 004 215 .0_	28	30	140	16	•							

### Protective Covers for Receptacles (IP 68) in Series B

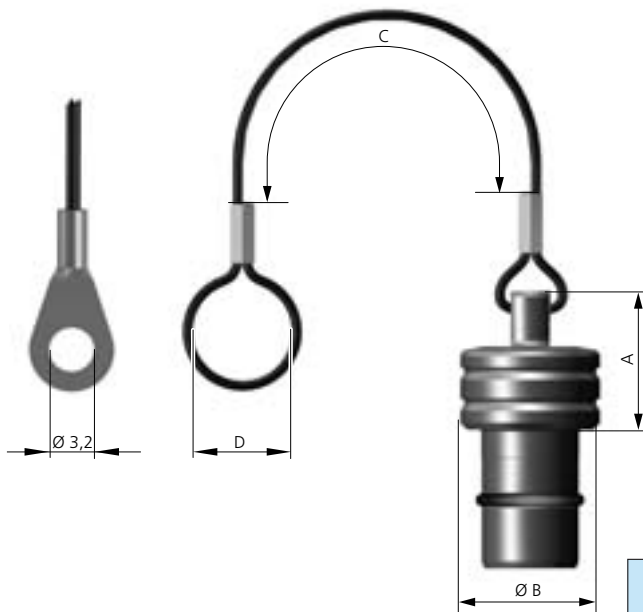

\* = With . please, register desired lanyard material  
 0 = Polyamide lanyard with loop  
 1 = Stainless steel lanyard with loop  
 2 = Polyamide lanyard solder lug  
 3 = Stainless steel lanyard solder lug  
 Surface: Matt chromate

Size	Part number*	Dimensions in mm			
		A	B	C	D
0	700 097 007 215 .00	10	10	70	8
1	701 097 007 215 .00	12	12	75	10
2	702 097 007 215 .00	15	15	85	13
3	703 097 007 215 .00	17.1	18	100	16

### Protective Covers for Plugs (IP 68) in Series B

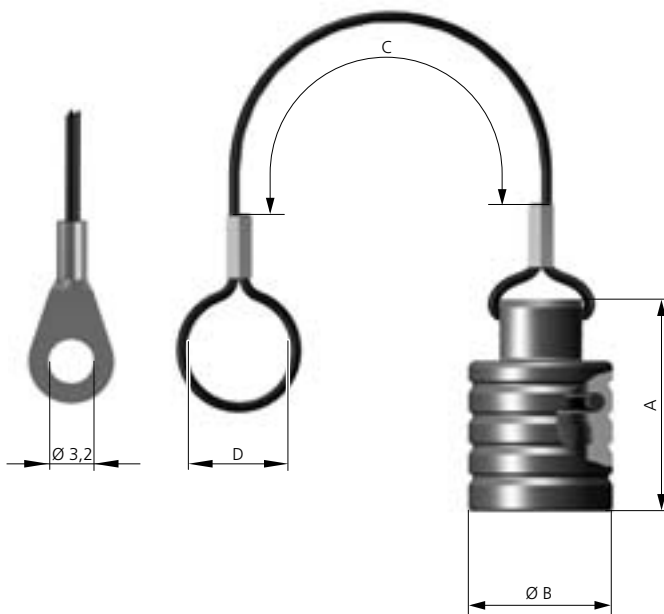

\* = With . please, register desired lanyard material  
 0 = Polyamide lanyard with loop  
 1 = Stainless steel lanyard with loop  
 2 = Polyamide lanyard solder lug  
 3 = Stainless steel lanyard solder lug  
 Surface: Matt chromate

Size	Part Number*	Dimensions in mm		
		A	B	C
0	700 097 004 215 .00	15.5	10.5	70
1	701 097 004 215 .00	16.5	13	75
2	702 097 004 215 .00	18.5	16	85
3	703 097 004 215 .00	21.0	19	100

Protective covers for A5 / A6 on request.

### Silicone-Cable Bend Relief for all Series

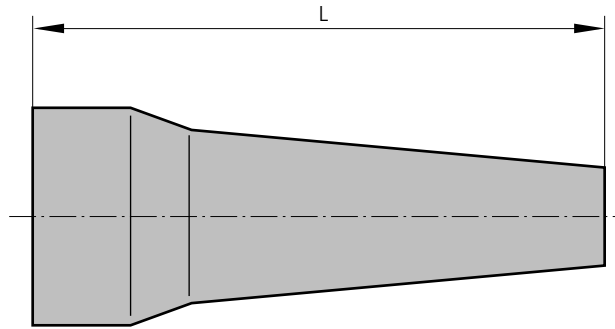

\* = In ... please indicate color code

Size	Part Number *	Dim. L	Cable O.D.	
			min.	max.
00	713 023 ... 965 005	19	> 0.5	1.5
00	713 023 ... 965 015	19	> 1.5	2.5
00	713 023 ... 965 025	19	> 2.5	3.5
0	700 023 ... 965 020	27	> 2.0	2.5
0	700 023 ... 965 025	27	> 2.5	3.0
0	700 023 ... 965 030	27	> 3.0	3.5
0	700 023 ... 965 035	27	> 3.5	4.0
0	700 023 ... 965 040	27	> 4.0	4.5
0	700 023 ... 965 045	27	> 4.5	5.0
1	701 023 ... 965 025	30	> 2.5	3.0
1	701 023 ... 965 030	30	> 3.0	3.5
1	701 023 ... 965 035	30	> 3.5	4.0
1	701 023 ... 965 040	30	> 4.0	5.0
1	701 023 ... 965 050	30	> 5.0	6.0
1	701 023 ... 965 060	30	> 6.0	6.5
1	701 023 ... 965 070	30	> 6.5	7.5
2	702 023 ... 965 030	36	> 3.0	3.5
2	702 023 ... 965 035	36	> 3.5	4.0
2	702 023 ... 965 040	36	> 4.0	5.0
2	702 023 ... 965 050	36	> 5.0	6.0
2	702 023 ... 965 060	36	> 6.0	7.0
2	702 023 ... 965 070	36	> 7.0	8.0
2	702 023 ... 965 080	36	> 8.0	9.0
3	703 023 ... 965 040	42	> 4.0	5.0
3	703 023 ... 965 050	42	> 5.0	6.0
3	703 023 ... 965 060	42	> 6.0	7.0
3	703 023 ... 965 070	42	> 7.0	8.0
3	703 023 ... 965 080	42	> 8.0	9.0
3	703 023 ... 965 090	42	> 9.0	10.0
3	703 023 ... 965 100	42	> 10.0	11.0
3	703 023 ... 965 110	42	> 11.0	12.0
4	704 023 ... 965 080	60	> 8.0	10.0
4	704 023 ... 965 100	60	> 10.0	12.0
4	704 023 ... 965 120	60	> 12.0	14.0
4	704 023 ... 965 140	60	> 14.0	16.0

Color Code	Color	RAL-Nr. (similar)
202	red	3020
203	white	9010
204	yellow	1016
205	green	6029
206	blue	5002
207	grey	7005
208	black	9005

Because of different raw materials the colors may slightly differ from RAL numbers.

#### Temperature range

Silicone -50°C up to +200°C  
Short-term up to +230°C autoclavable

### Locking Washers for Series L and B

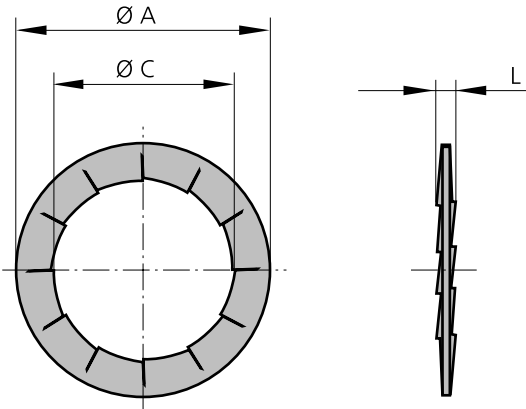

#### Mounting example:

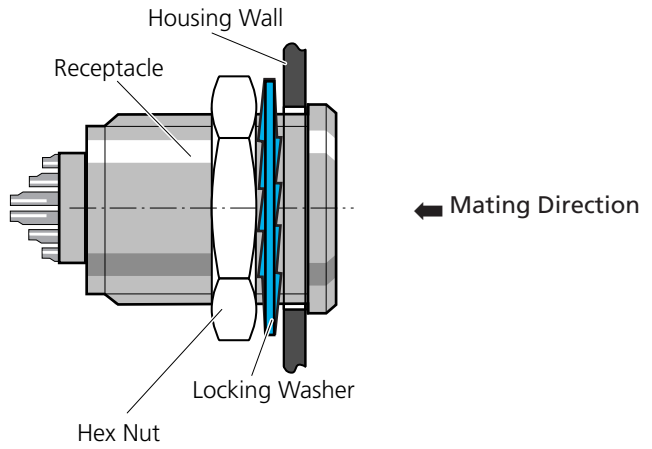

Nickel-plated surface

Size	Part number	Dimensions in mm		
		A	C	L
M7	945 000 001 000 057	9.5	7.1	1.0
M9	945 000 001 000 046	12.5	9.1	1.0
M12	945 000 001 000 047	16.0	12.1	1.1
M14	945 000 001 000 070	19.5	14.2	1.1
M15	945 000 001 000 048	19.3	15.1	1.1
M16	945 000 001 000 072	21.5	16.1	1.1
M18	945 000 001 000 049	25.0	18.1	1.1
M20	945 000 001 000 121	25.0	20.1	1.1
M25	945 000 001 000 086	32.0	25.1	1.4
M35	945 000 001 000 084	41.0	35.5	1.4

### Solder Lugs for Series L and B

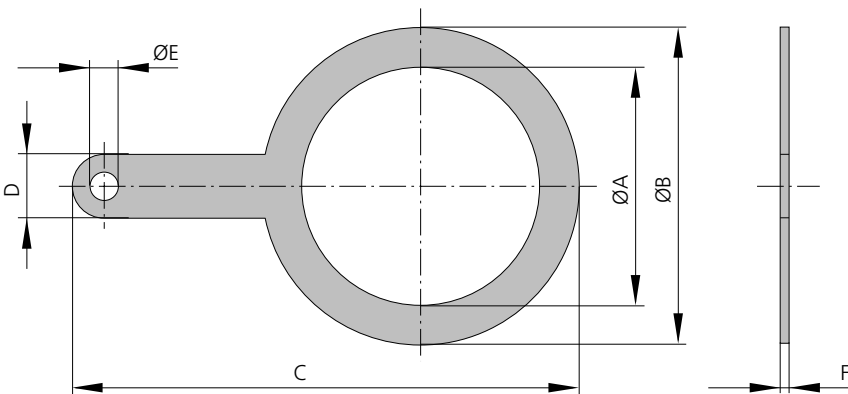

#### Mounting example:

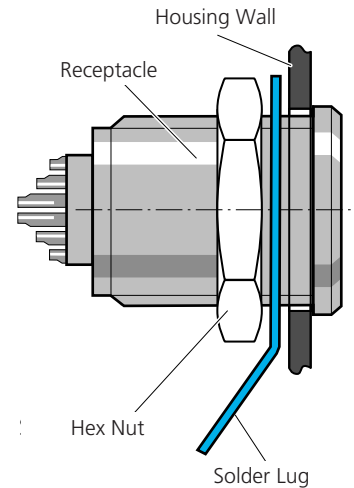

Silver-plated surface

Thread	Part number	Dimensions in mm					
		A	B	C	D	E	F
M7	713 140 246 301 000	7.4	10.0	17.0	4	3.1	0.3
M9	700 140 246 301 000	9.7	13.2	21.6	4	1.6	0.5
M12	701 140 246 301 000	12.2	17.0	27.5	4	1.6	0.5
M14	715 140 246 301 000	14.1	18.0	27.0	4	2.0	0.5
M15	702 140 246 301 000	15.2	20.0	32.0	4	1.6	0.5
M16	721 140 246 301 000	16.2	20.0	32.0	4	1.6	0.5
M18	703 140 246 301 000	18.2	25.0	39.0	4	1.6	0.5
M20	722 140 246 301 000	20.2	25.0	39.0	4	1.6	0.5
M25	704 140 246 301 000	25.6	35.0	51.0	5	2.1	0.6
M35	705 140 246 301 000	35.5	41.0	57.0	5	2.1	0.6

### Distance Ring for Wall Thickness Adjustment for style 2 in Series B

(see page 60)

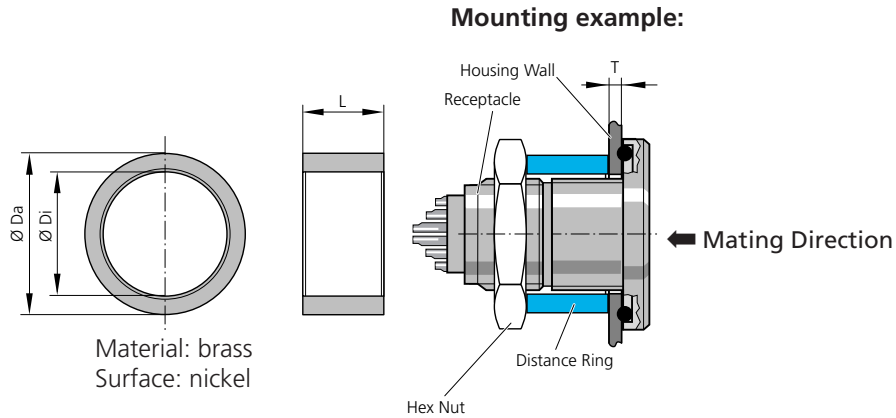

Material: brass  
Surface: nickel

Part number	Size	Da	Di	L	T
700 123 102 304 000	0	13	10.3	7	1-6
701 123 102 304 000	1	17	14.3	12	0.5-6
701 123 102 304 001	1	17	14.3	6	6-16
702 123 102 304 000	2	21	16.3	8	1-9
703 123 102 304 000	3	25	20.3	11.5	0.5-7

### Backnut for Silicone-Cable Bend Relief

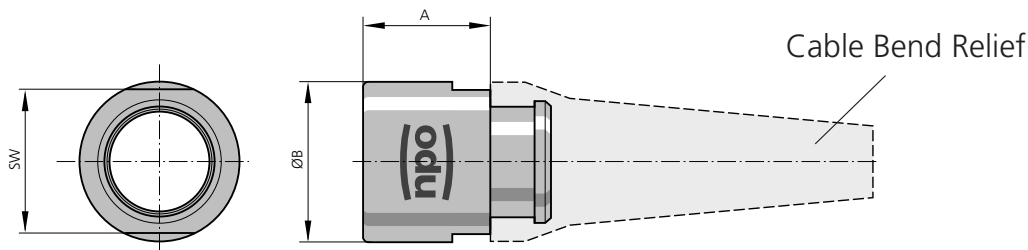

\* = In ... please indicate surface finish:  
 15 = Cu-alloy / matt chromate  
 11 = Cu-alloy / black chromate  
 04 = Cu-alloy / nickel

Size	Part number A	Dimensions in mm			Series		
		ØB	SW		L	B	K
00	713 022 117 3.. 000	6.0	6.4	5	•		
0	700 022 117 3.. 002	8.0	8.9	7	•	•	•
1	701 022 117 3.. 002	10.0	11.2	10	•	•	•
2	702 022 117 3.. 002	11.5	13.9	13	•	•	•
3	703 022 117 3.. 002	11.5	16.9	15		•	
3	753 022 117 3.. 002	11.5	16.5	15	•		•
4	704 022 117 3.. 002	15.0	23.0	20	•	•	•

# Tools



## Crimping Tools

### 8-point-crimptong

**Order-Nr.: 080.000.037.000.000**

for crimp contacts: 0.7 mm and 0.9 mm.  
cross section: 0.08 mm<sup>2</sup> up to 0.5 mm<sup>2</sup>

You can find all informations about adjustment and using of this tools on page 109

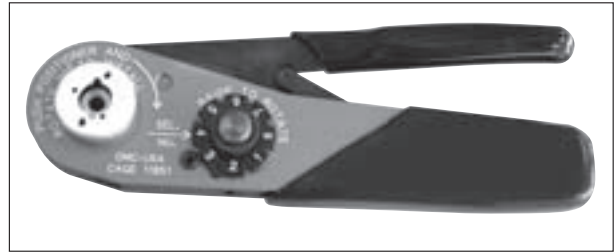

### 8-point-crimptong

**Order-Nr.: 080.000.038.000.000**

for crimp contacts: 1.3 mm and 1.6 mm.  
for cross section: 0.38 mm<sup>2</sup> up to 2.5 mm<sup>2</sup>

You can find all informations about adjustment and using of this tools on page 109

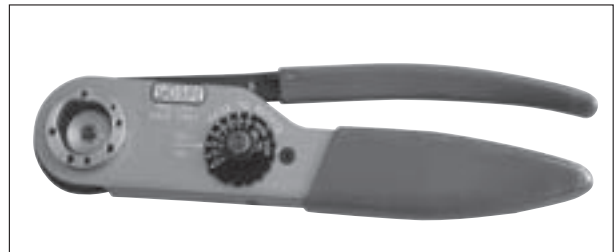

### Pneumatic crimping tool

**Order-Nr.: 080.000.032.000.000**

For all MINI-SNAP contacts applicable  
cross section: 0.08 mm<sup>2</sup> up to 2.5 mm<sup>2</sup>

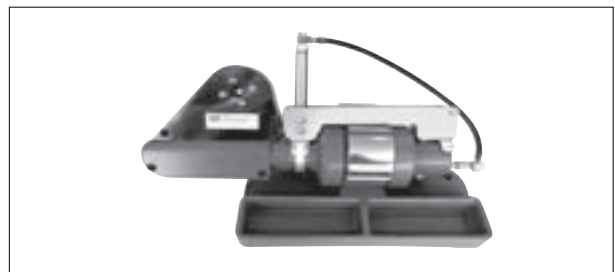

## Crimping and Removal Tools for Crimp Contacts (037 and 038)

Position	Size	AWG	mm <sup>2</sup>	Adjustment	Adjustment	Positionier		Removal Tool
				037 Crimptool 080.000.037.000.000	038 Crimptool 080.000.038.000.000	Socket	Pin	
2	0	22-26	0.38-0.15	4	-	081 700 004 749 037	081 701 002 849 037	087 7CC 090 001 000
		20/22/24	0.50/0.38/0.25	7/6/5	-	081 700 003 749 037	081 701 003 849 037	
3	0	22-26	0.38-0.15	4	-	081 700 004 749 037	081 701 002 849 037	087 7CC 090 001 000
		20/22/24	0.50/0.38/0.25	7/6/5	-	081 700 003 749 037	081 701 003 849 037	
4	0	28-32	0.09-0.04	3	-	081 700 005 748 037	081 701 002 848 037	087 7CC 070 001 000
		22-26	0.38-0.15	4	-			
5	0	28-32	0.09-0.04	3	-	081 700 005 748 037	081 701 002 848 037	087 7CC 070 001 000
		22-26	0.38-0.15	4	-			
2	1	18-20	1.0-0.50	-	5	081 701 002 744 038	081 701 002 844 038	087 7CC 130 001 000
3	1	18-20	1.0-0.50	-	5	081 701 002 744 038	081 701 002 844 038	087 7CC 130 001 000
4	1	22-26	0.38-0.15	4	-	081 701 002 749 037	081 701 002 849 037	087 7CC 090 001 000
		20/22/24	0.50/0.38/0.25	7/6/5	-	081 701 003 749 037	081 701 003 849 037	
5	1	22-26	0.38-0.15	4	-	081 701 002 749 037	081 701 002 849 037	087 7CC 090 001 000
		20/22/24	0.50/0.38/0.25	7/6/5	-	081 701 003 749 037	081 701 003 849 037	
6	1	28-32	0.09-0.04	3	-	081 701 002 748 037	081 701 002 848 037	087 7CC 070 001 000
		22-26	0.38-0.15	4	-			
7	1	28-32	0.09-0.04	3	-	081 701 002 748 037	081 701 002 848 037	087 7CC 070 001 000
		22-26	0.38-0.15	4	-			
8	1	28-32	0.09-0.04	3	-	081 701 002 748 037	081 701 002 848 037	087 7CC 070 001 000
		22-26	0.38-0.15	4	-			
2	2	14-18	1.5-1.0	-	6	081 702 001 702 038	081 702 001 802 038	087 7CC 200 002 000
		12-14	2.5-1.5	-	7			
3	2	14-18	1.5-1.0	-	6	081 702 001 751 038	081 702 001 851 038	087 7CC 160 001 000
4	2	18-20	1.0-0.50	-	5	081 702 001 744 038	081 702 001 844 038	087 7CC 130 001 000
		20-24	0.50/0.38/0.25	-	2/2/1	081 702 002 744 038	081 702 002 844 038	
5	2	18-20	1.0-0.50	-	5	081 702 001 744 038	081 702 001 844 038	087 7CC 130 001 000
		20-24	0.50/0.38/0.25	-	2/2/1	081 702 002 744 038	081 702 002 844 038	
6	2	18-20	1.0-0.50	-	5	081 702 001 744 038	081 702 001 844 038	087 7CC 130 001 000
		20-24	0.50/0.38/0.25	-	2/2/1	081 702 002 744 038	081 702 002 844 038	
7	2	18-20	1.0-0.50	-	5	081 702 001 744 038	081 702 001 844 038	087 7CC 130 001 000
		20-24	0.50/0.38/0.25	-	2/2/1	081 702 002 744 038	081 702 002 844 038	
8	2	22-26	0.38-0.15	4	-	081 702 003 749 037	081 701 002 849 037	087 7CC 090 001 000
		20/22/24	0.50/0.38/0.25	7/6/5	-	081 702 002 749 037	081 701 003 849 037	
10	2	22-26	0.38-0.15	4	-	081 702 003 749 037	081 701 002 849 037	087 7CC 090 001 000
		20/22/24	0.50/0.38/0.25	7/6/5	-	081 702 002 749 037	081 701 003 849 037	
12	2	28-32	0.09-0.04	3	-	081 702 001 748 037	081 702 001 848 037	087 7CC 070 001 000
		22-26	0.38-0.15	4	-			
14	2	28-32	0.09-0.04	3	-	081 702 001 748 037	081 702 001 848 037	087 7CC 070 001 000
		22-26	0.38-0.15	4	-			
16	2	28-32	0.09-0.04	3	-	081 702 001 748 037	081 702 001 848 037	087 7CC 070 001 000
		22-26	0.38-0.15	4	-			
18	2	28-32	0.09-0.04	3	-	081 702 001 748 037	081 702 001 848 037	087 7CC 070 001 000
		22-26	0.38-0.15	4	-			
19	2	28-32	0.09-0.04	3	-	081 702 001 748 037	081 702 001 848 037	087 7CC 070 001 000
		22-26	0.38-0.15	4	-			
7	3	18-20	1.0-0.5	-	5	081 703 002 751 038	081 702 001 851 038	087 7CC 160 001 000
		14-18	1.5-1.0	-	6			
14	3	22-26	0.38-0.15	4	-	081 703 003 749 037	081 701 002 849 037	087 7CC 090 001 000
		20/22/24	0.50/0.38/0.25	7/6/5	-	081 701 003 849 037	081 701 003 849 037	
18	3	22-26	0.38-0.15	4	-	081 703 003 749 037	081 701 002 849 037	087 7CC 090 001 000
		20/22/24	0.50/0.38/0.25	7/6/5	-	081 701 003 849 037	081 701 003 849 037	
20	3	28-32	0.09-0.04	3	-	081 703 002 748 037	081 702 001 848 037	087 7CC 070 001 000
		22-26	0.38-0.15	4	-			
22	3	28-32	0.09-0.04	3	-	081 703 002 748 037	081 702 001 848 037	087 7CC 070 001 000
		22-26	0.38-0.15	4	-			
26	3	28-32	0.09-0.04	3	-	081 703 002 748 037	081 702 001 848 037	087 7CC 070 001 000
		22-26	0.38-0.15	4	-			
30	3	28-32	0.09-0.04	3	-	081 703 002 748 037	081 702 001 848 037	087 7CC 070 001 000
		22-26	0.38-0.15	4	-			

The Crimp information does only apply for Crimp-Clip-Contacts!

**Order example for the tongs type 037 and 038:**

Assumed Connector: S12LOC-T08PJH0-7200

In this size 2 connector is a 8-way Pin Insert used.

The contact diameter is 0.9 mm.  
The cable cross section is AWG 20/22

Therefore you have to order following tools:

**080.000.037.000.000 Crimp Tong 037 (Adjustment 7)**  
**081.702.001.849.037 Positionier for Pin Contacts**  
**085.180.689.000.000 Removal tool**  
**702.098.004.300.000 Assembly Jig**

You can find all informations about adjustment and using of this tools on page 110.

**Adjustment of the Crimp Tongs 080.000.037.000.000 and 080.000.038.000.000**  
(see page 109)

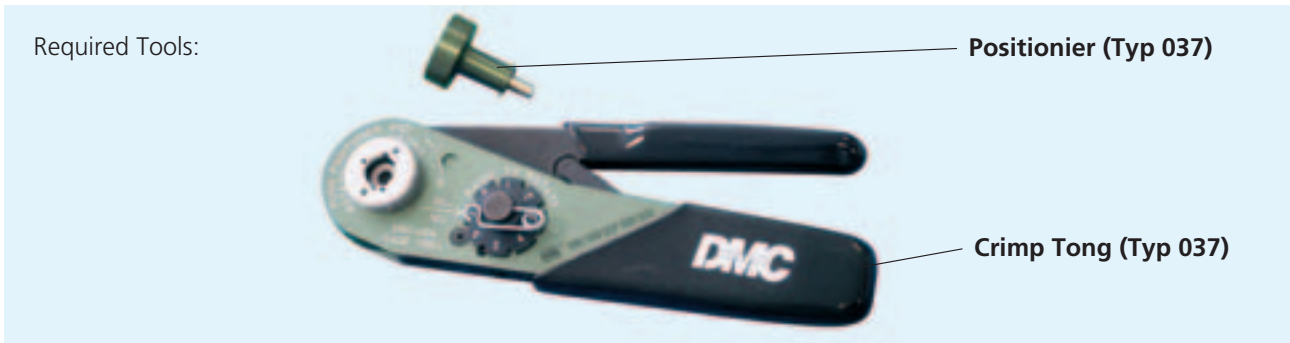

**1. Fasten the Positionier on the Crimp Tong**



Please fasten the Positionier under consideration of the guiding into the tong



037: Thereby push the positionier down and turn it right at the same time.

038: You don't have to do this with this tong.



037: To fix the positionier in this position, you have to use the attached safety pin.

038: Here you have to fix the positionier with some attached allen screw and the suitable spanner.

**2. Adjust of the Crimp Tong for the cable cross section**



Please turn the adjustment wheel onto the right position. If the adjustment is done, so please fix the wheel with the attached safety pin.

Now the tong is ready adjusted. You can start with the crimp process

### Spanner Wrench

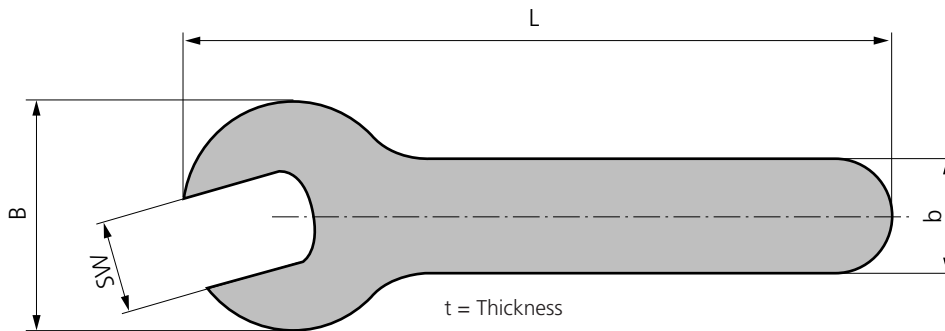

Order No.	SW	t	B	L	b
598.700.001.016.000	5	1.5	18.5	92	8
598.700.001.015.000	5.5	1.5	18.5	92	8
598.700.001.021.000	6	2	18.5	92	8
598.700.001.011.000	7	2	18.5	92	8
598.700.001.001.000	8	2	18.5	92	8
598.700.001.022.000	9	2	21.5	102	9
598.700.001.002.000	10	2	21.5	102	9
598.700.001.012.000	11	2	24.5	115	10
598.700.001.003.000	12	2.5	24.5	115	10
598.700.001.017.000	12.5	4	24.5	115	10
598.700.001.004.000	13	2.5	30.5	98	16.5
598.700.001.005.000	14	2.5	30.5	98	16.5
598.700.001.006.000	15	3	35.5	145	15
598.700.001.007.000	16	3	35.5	145	15
598.700.001.008.000	17	3	35.5	145	15
598.700.001.023.000	18	3	42	172	16
598.700.001.013.000	19	3	42	172	16
598.700.001.009.000	20	3	42	172	16
598.700.001.018.000	21	3	42	172	16
598.700.001.010.000	22	3	47	119	23.5
598.700.001.014.000	24	3	47	119	23.5
598.700.001.019.000	30	3	50	150	25
598.700.001.020.000	31	3	50	150	25

### Nutdriver for Slotted Mounting Nut

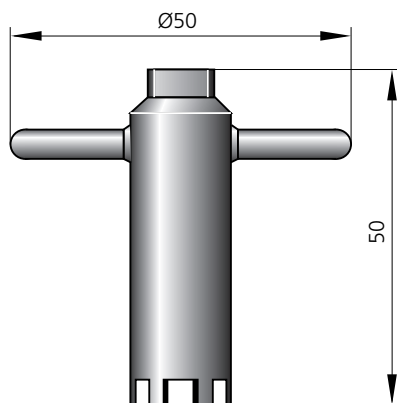

suitable for style 8 / Series L and B

Nutdriver	Thread
700 098 002 000 000	M 9x0.5
700 098 001 000 000	M 10x0.5
700 098 001 000 000	M 12x1
701 098 002 000 000	M 14x1
701 098 001 000 000	M 15x1
702 098 001 000 000	M 16x1
702 098 001 000 000	M 18x1
703 098 001 000 000	M 20x1

suitable for style 3 / Series K

Nutdriver	Thread
701 098 002 000 000	M 14x1
721 098 001 000 000	M 16x1
703 098 001 000 000	M 20x1
724 098 001 000 000	M 30x1

## Removal tool for Crimp-Clip-Contacts



Part-Number	Contact Ø
087 7CC 050 001 000	0.5 mm
087 7CC 070 001 000	0.7 mm
087 7CC 090 001 000	0.9 mm
087 7CC 130 001 000	1.3 mm
087 7CC 160 001 000	1.6 mm

Crimp-Clip-Contact



## Assembly tool series K

**Order-Nr.: 080.000.055.000.000**

- Useable from Size 0 until 4
- To clamp the inner housing for back nut assembly
- Incl. jaws for bench vise fixing for easy handling



# Assembly Instructions



# Assembly Instruction

## For unsealed Connectors Series L (IP 50)

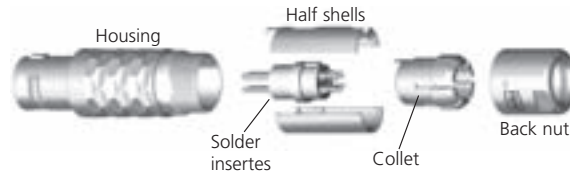

1. Slide Back nut and Collet over the cable.



2. Strip cable and wire  
3. Pre-tinning of strands recommended



4. Solder each wire to the corresponding contact

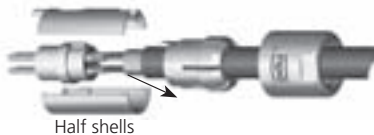

5. Bend cable shield outwards, assemble half shells.

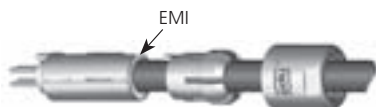

6. Slide the EMI-Ring against the sleeve and clamp the shield between it.

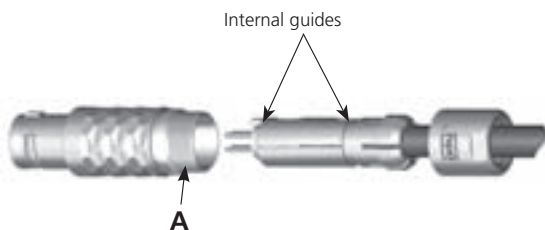

7. Now you can put the assembled cable into the plug-housing. If needed, secure thread (A) with locking glue.

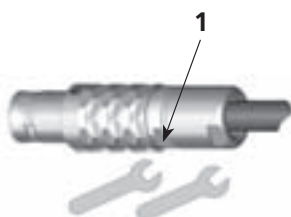

8. Screw back nut on the plug, hold against flat 1 and fasten cable in the housing\*.

**Attention!** Torque value:

Size	00	0	1	2	3	4
Nm	0.5	0.6	1.0	2.0	3.5	4

Now the plug is assembled.

\* ODU-Spanner-Wrench: see page 111

# Assembly Instruction

## For unsealed right-angle plug connectors (IP 50), series L

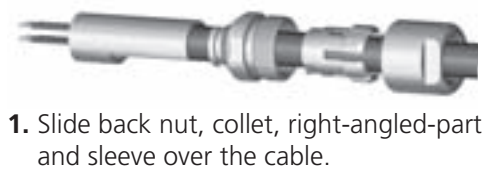
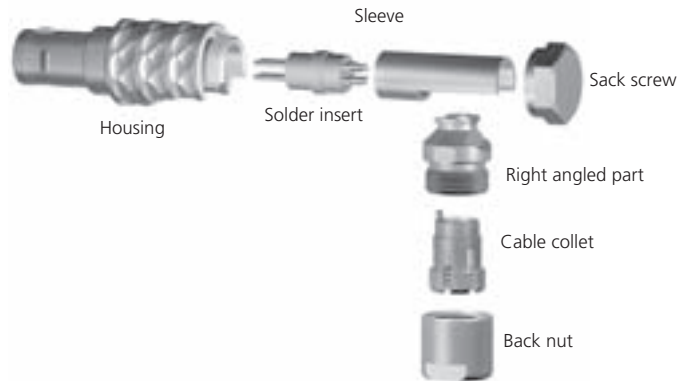

1. Slide back nut, collet, right-angled-part and sleeve over the cable.



2. Strip cable and wire  
3. Pre-tinning of strands recommended



4. Solder each wire to the corresponding contact (Crimp version see straight Connector to Page 118)



5. Pull cable back and bend 90° down. Spread the cable shield over collet ring. Slide sleeve over insulator.

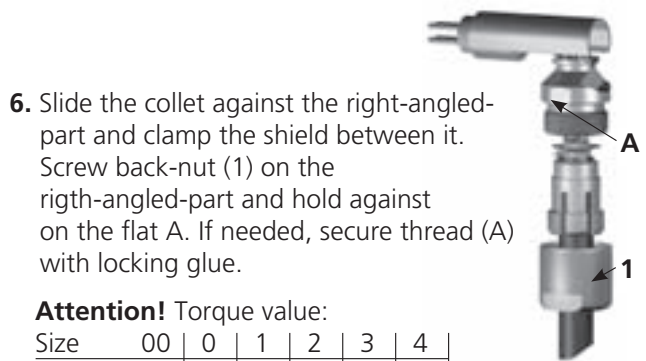

6. Slide the collet against the right-angled-part and clamp the shield between it. Screw back-nut (1) on the righth-angled-part and hold against on the flat A. If needed, secure thread (A) with locking glue.

**Attention!** Torque value:

Size	00	0	1	2	3	4
Nm	0.5	0.6	1.0	2.0	3.5	8



7. Now you can put the assembled cable into the plug-housing.

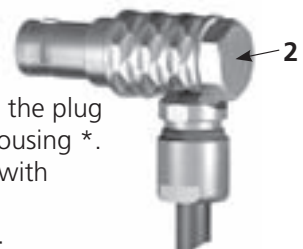
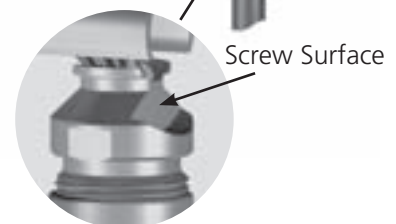

8. Mount back-screw (2) on the plug and fasten cable in the housing \*. If needed, secure thread with locking glue.

**Attention!** Torque value:

Size	00	0	1	2	3	4
Nm	0.2	0.3	0.4	0.9	1.3	2.0

Now the plug is assembled.

\* ODU-Spanner-Wrench: see page 111

# Assembly Instruction

## For sealed connectors (IP 68) Series K

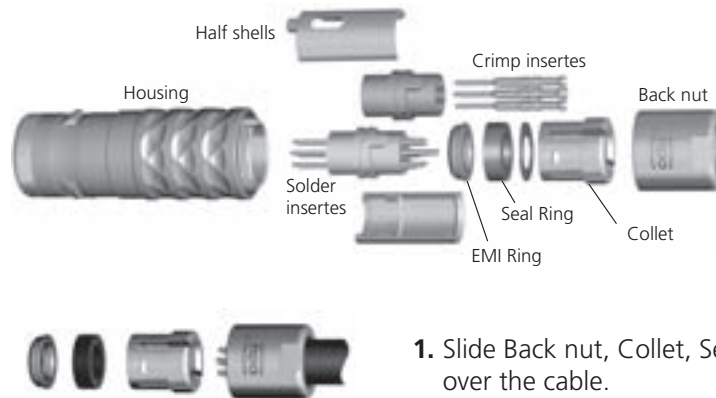

1. Slide Back nut, Collet, Seal Ring and EMI-Ring over the cable.

### Crimp termination

Detail information see page 108-109



Part number see page 108

2. Strip cable and wire
3. Fit wire into the contact barrel and crimp



Part number see page 109

4. Insert contacts into insulator, use the insertion tool to push them in



Half shells

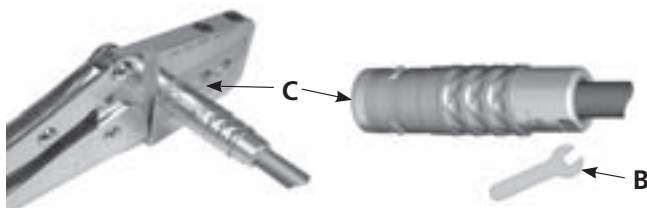
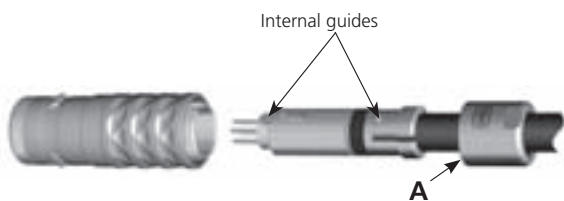

### Solder termination



2. Strip cable and wire
3. Pre-tinning of strands recommended



Solder iron

4. Solder each wire to the corresponding contact
5. Bend cable shield outwards, assemble half shells.
6. Slide the EMI-Ring against the sleeve and clamp the shield between it.
7. Now you can put the assembled cable into the plug-housing. If needed, secure thread (A) with locking glue.
8. Screw back nut on the plug and fasten cable in the housing. Tighten with ODU-Spanner-Wrench (B) and hold against with ODU tongs 080.000.055.000.000 (C).

**Attention!** Torque value:

Size	0	1	2	3	4
Nm	0.6	1.0	2.0	3.5	3.5

Now the plug is assembled.

\* ODU-Spanner-Wrench: see page 111

**Watertight connectors require a grommet seal designed for the intended cable. We require either the exact specification or a sample of the cable.**

# Assembly Instruction

## For sealed right-angle plug connectors (IP 68) Series K

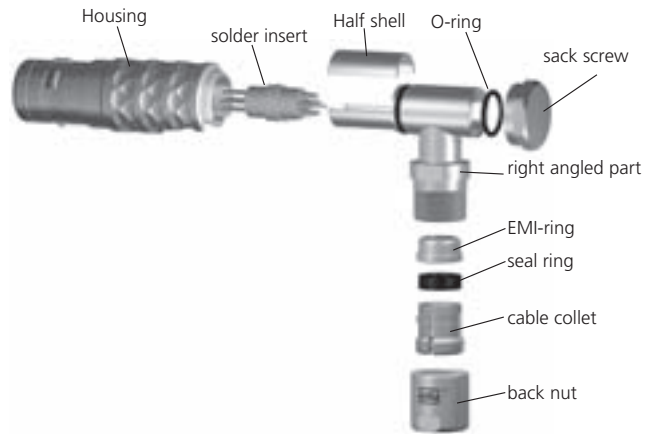

1. Slide back nut, collet, seal ring, EMI-ring and right-angled-part over the cable.
2. Strip cable and wire
3. Pre-tinning of strands recommended



6. Slide collet, seal ring and EMI-ring against the right-angled-part and clamp the shield between EMI-ring and right-angled-part. Screw back-nut (1) on the right-angled-part and hold against on flat (A). Please halfshell over insulator. If needed, secure thread with locking glue.

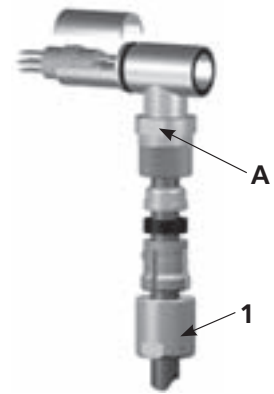

**Attention!** Torque value:

Size	0	1	2	3
Nm	0.6	1.0	2.0	3.5

4. Solder each wire to the corresponding contact (Crimp version see straight Connector to Page 116)



7. Now you can put the assembled cable into the plug-housing.



5. Pull cable back. Spread the cable shield over collet ring.



8. Mount back-screw (2) on the plug and fasten cable in the housing. If needed, secure thread with locking glue.

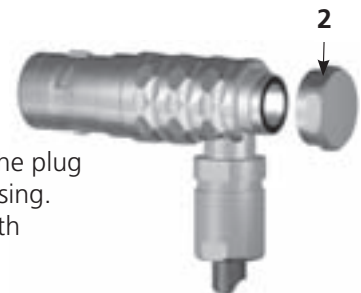

**Attention!** Torque value:

Size	0	1	2	3
Nm	0.3	0.4	0.9	1.3

Now the plug is assembled.

\* ODU-Spanner-Wrench: see page 111

# Assembly Instruction

## For sealed connectors Series B (IP 68)

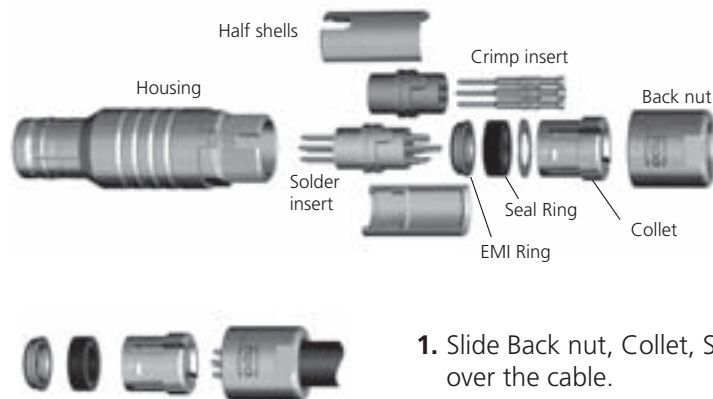

1. Slide Back nut, Collet, Seal Ring and EMI-Ring over the cable.

### Crimp termination

Detail information see page 108-109



Part number see page 108

2. Strip cable and wire
3. Fit wire into the contact barrel and crimp



Part number see page 109

4. Insert contacts into insulator, use the insertion tool to push them in



Half shells

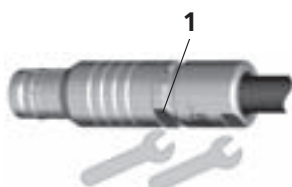
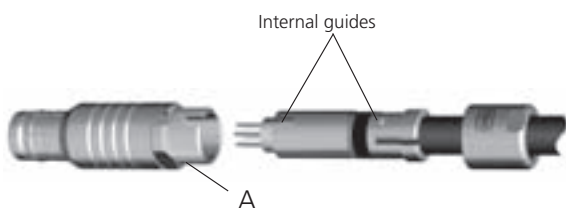

### Solder termination



2. Strip cable and wire
3. Pre-tinning of strands recommended



4. Solder each wire to the corresponding contact

5. Bend cable shield outwards, assemble half shells.

6. Slide the EMI-Ring against the sleeve and clamp the shield between it.

7. Now you can put the assembled cable into the plug-housing. If needed, secure thread (A) with locking glue.

8. Screw back nut on the plug, hold against flat 1 and fasten cable in the housing\*.

**Attention!** Torque value:

Size	0	1	2	3
Nm	0.6	1.0	2.0	3.5

Now the plug is assembled.

\* ODU-Spanner-Wrench: see page 111

**Watertight connectors require a grommet seal designed for the intended cable. We require either the exact specification or a sample of the cable.**

# Assembly Instruction

## For sealed right-angle plug connectors (IP 68) Series B

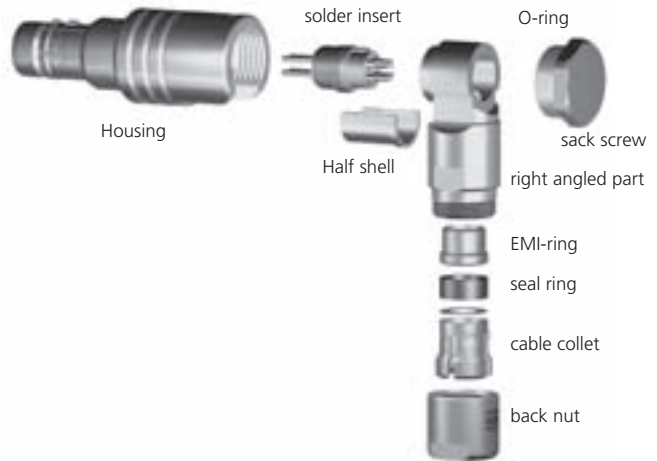

1. Slide back nut, collet, seal ring, EMI-ring and right-angled-part over the cable.
2. Strip cable and wire
3. Pre-tinning of strands recommended



6. Slide collet, seal ring and EMI-ring against the right-angled-part and clamp the shield between EMI-ring and right-angled-part. Screw back-nut (1) on the right-angled-part and hold against on flat (A). Please halfshell over insulator. If needed, secure thread with locking glue.

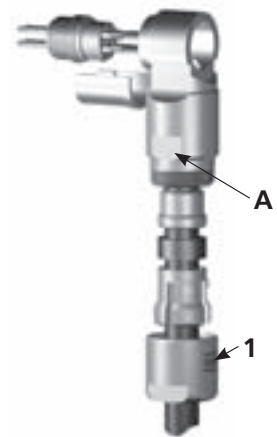

**Attention!** Torque value:

Size	0	1	2	3
Nm	0.6	1.0	2.0	3.5

4. Solder each wire to the corresponding contact (Crimp version see straight Connector to Page 118)



Part No.700 412 106 000 000



7. Now you can put the assembled cable into the plug-housing.

5. Pull cable back. Spread the cable shield over collet ring.

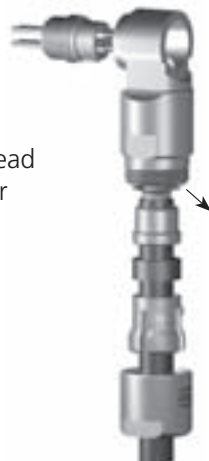

8. Mount back-screw (2) on the plug and fasten cable in the housing. If needed, secure thread with locking glue.

**Attention!** Torque value:

Size	0	1	2	3
Nm	0.3	0.4	0.9	1.3

Now the plug is assembled.

\* ODU-Spanner-Wrench: see page 111

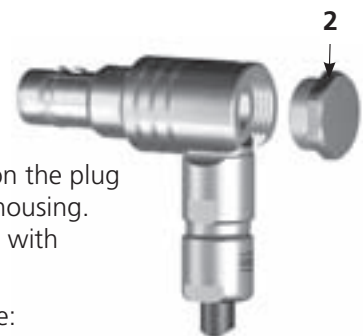

## Torque for back-nuts

### Torque for styles

- Straight plug S1; S2; S3; S4
- Right-angled-plug W1; W2; W3; W4
- Break-apart-plug A5; A6; A7; A8
- In-line-receptacle K1; K2; K3; K4
- Receptacle G6; G7

Size	00	0	1	2	3	4
Torque	0.5 Nm	0.6 Nm	1.0 Nm	2.0 Nm	3.5 Nm	4 Nm

1 Nm = 8.85 inch-pounds

## Cable Preparation:

The following Table provides recommended guidelines for cable preparation.

The according stripping measures have to be checked before assembly!

By the huge number of the different connectors partially the measures from the table mentioned below can differ.

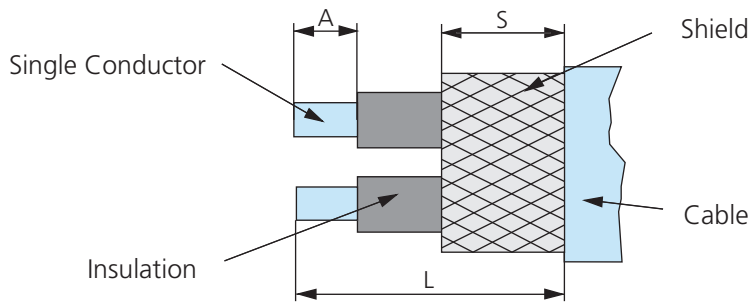

A = Stripping length single conductor

L = Stripping length cable jacket

S = Stripping length braided shield

Size	Straight Plug						Right-angled Plug Series L						Right-angled Plug IP68 Series B						
	Solder Termination			Crimp Termination			Solder Termination			Crimp Termination			Solder Termination			Crimp Termination			
	L	A	S	L	A	S	L	A	S	L	A	S	L	A	S	L	A	S	
00	5	2	2	-	-	-	11	2	2	-	-	-	-	-	-	-	-	-	-
0	7	2	2.5	10	3	2.5	16	2	2.5	21	3	2.5	18	2	2.5	21	3	2.5	
1	9	2	2.5	12	3	2.5	18	2	2.5	21	3	2.5	18	2	2.5	21	3	2.5	
2	11	2	2.5	14	3	2.5	27	2	2.5	30	3	2.5	27	2	2.5	30	3	2.5	
3	13	2	2.5	17	3	2.5	30	2	2.5	32	3	2.5	28	2	2.5	32	3	2.5	

All dimensions in mm

Exceptions are noted on special instructions.

Right-angle plugs have special instructions.

# Technical Information

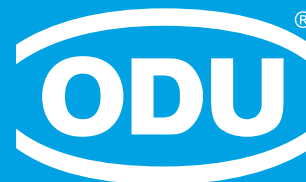
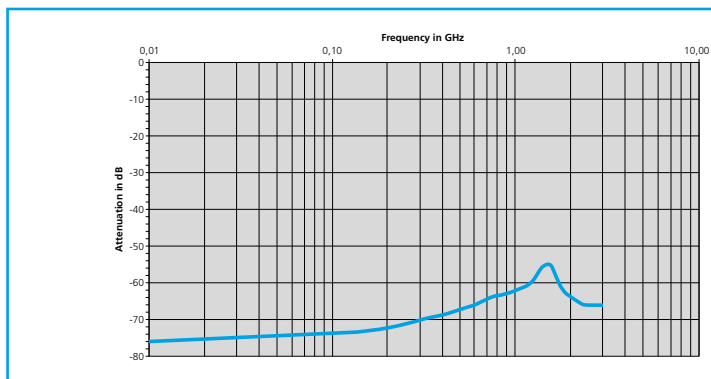

## INDEX:

International Protection (IP) Classes (DIN EN 60 529) .....	122
Watertightness of the ODU MINI-SNAP .....	123
Operating Voltage acc. to SAE AS 13441-method 3001.1 .....	124
Current Load - Contacts .....	125
Termination Styles .....	126
Conversion Table AWG to Metric .....	127
Housing Materials / Surfaces .....	128
Electromagnetic Compatibility (EMC) .....	129
Autoclaving of ODU MINI-SNAP .....	130
Quality Management .....	131
Tests acc. to MIL .....	132
Technical Terms & Definitions .....	133

## International Protection (IP) Classes DIN EN 60 529 (respectively IEC 529 / VDE 0470 T1)

The housing and the locking system of the ODU MINI-SNAP protect the contacts against outside mechanical influence, such as impact shocks, impurities, dust, unintended contact and penetration of moisture, water or other liquids (coolants, oils, etc.).

Protection classification is indicated with the letters **IP** and two numbers.

IP: International Protection















**All IP 68 submersible ODU MINI-SNAP Connectors are rated to 2m water depth (0.2 bar) for 24 hours in accordance with DIN EN 60529.**

A watertight plug requires a cable grommet in the collet. The grommet has to fit tightly over the cable.

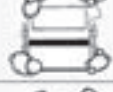
The cable jacket must be smooth, cylindrical and free of grooves.

The plug should be potted for watertightness in unmated condition.

(Higher requirements for Watertightness on request)

Code letters (International Protection)		First Index Figure (Foreign bodies protection)	Second Index Figure (Water protection)
<b>IP</b>		<b>6</b>	<b>8</b>
Index	Degree of protection	Index	Degree of protection
<b>0</b>	 No protection against accidental contact, no protection against intrusion of solid foreign bodies	<b>0</b>	No protection against water
<b>1</b>	 Protection against contact with any large area by hand and against large solid foreign bodies with $\varnothing > 50$ mm	<b>1</b>	 Protection against vertical water drips
<b>2</b>	 Protection against contact with the fingers, protection against large solid foreign bodies with $\varnothing > 12$ mm	<b>2</b>	 Protection against water drips (up to a 15° angle)
<b>3</b>	 Protection against tools, wires or similar objects with $\varnothing > 2.5$ mm. Protection, against small foreign solid bodies with $\varnothing > 2.5$ mm	<b>3</b>	 Protection against diagonal water drips (up to a 60° angle)
<b>4</b>	 As 3 however $\varnothing > 1$ mm	<b>4</b>	 Protection against splashed water from all directions
<b>5</b>	 Full protection against contact. Protection against interior detrimental dust deposition.	<b>5</b>	 Protection against water spray from all directions
<b>6</b>	 Total protection against contact. Protection against intrusion of dust	<b>6</b>	 Protection against temporary flooding
		<b>7</b>	 Protection against temporary immersion
		<b>8</b>	 Protection against water pressure

In accordance with DIN VDE 0470, DIN EN 60 529, IEC 529  
Source: ZVEI = German Association of the Electrotechnical and Electronic Industry e.V.

## Watertightness of the ODU MINI-SNAP

➔ ODU offers IP 50 and IP 68 connectors in series B and S in the same outside diameter. Because ODU connectors must be compatible with other manufacturers, the company also offers the series K. These connector is larger in diameter than the standard version (series L).

I) In-line receptacle

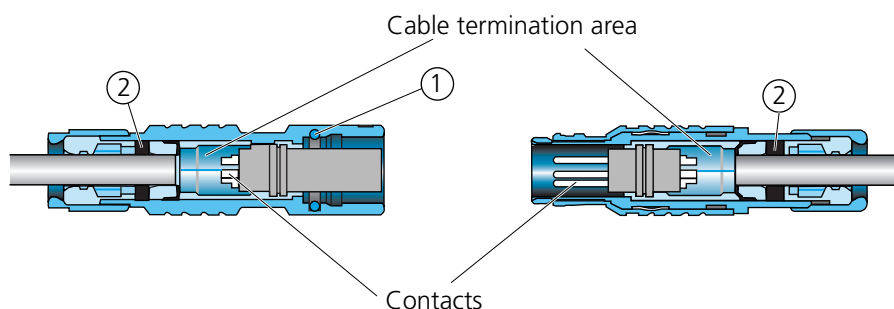

Sealing Part	
①	O-ring
②	Grommet *2
③	O-ring
④	Potting

II)

Receptacle

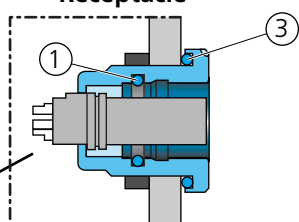

Plug

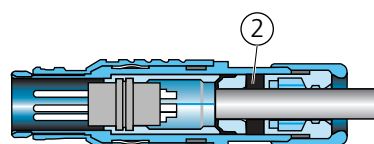

III)

Cable -

Receptacle

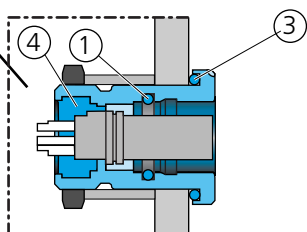

Plug

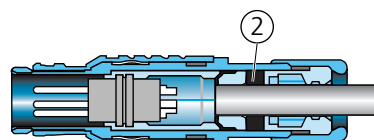

Protection against Water through following seals: \*1

		mated	unmated
I	Cable – Cable termination area	Yes ① + ②	No
II	Device – Cable termination area	Yes ① + ③ + ②	No
III	Device – Cable termination area	Yes ① + ③ + ②	Yes ③ + ④

\*1 Contacts: in mated condition the contacts are protected (in cases I, II, III) . In unmated condition the contacts can be protected using a protective cover (see page 101–103). The cover must be removed before mating the plug with the receptacle.

\*2 The elastic grommet acts as the cable seal. It requires exact knowledge of the cable dimension.  
**Important factors:** Diameter tolerance, roundness, cable design and cable jacket hardness.

## Operating voltage acc. to SAE AS 13441-method 3001.1

The values acc. to SAE AS 13441-method 3001.1 comply with MIL-Std. 1344 – method 3001.

The chart values results are acc. to IEC 60512-2; Test 4. The inserts have been tested in mated condition and the test voltage was applied to the pin insert.

75% of the measured break-down voltage is the basic for the further calculation. 1/3 of this value is the corresponding operating voltage.

All tests were performed at standard environment conditions (room temperature) and can be applied up to an altitude of 2,000 m.

For any deviations one has to consider the reduction factor acc. to the relevant standards.

**Test voltage:** **Break-down voltage x 0.75**

**Operating voltage:** **Break-down voltage x 0.75 x 0.33**

### Caution:

Electrical appliances: for various applications the safety requirements regarding the operating voltage is even more severe!

The relevant data in such cases for the operating voltage are the creepage and clearance distances. For any advise how to chose the proper connector please consult us and indicate the safty standard which your product has to meet.

## Current Load – Contacts

### Nominal Single Contact Current Load for pin / slotted socket

(Nominal Diameter 0.5 mm – 1.6 mm)

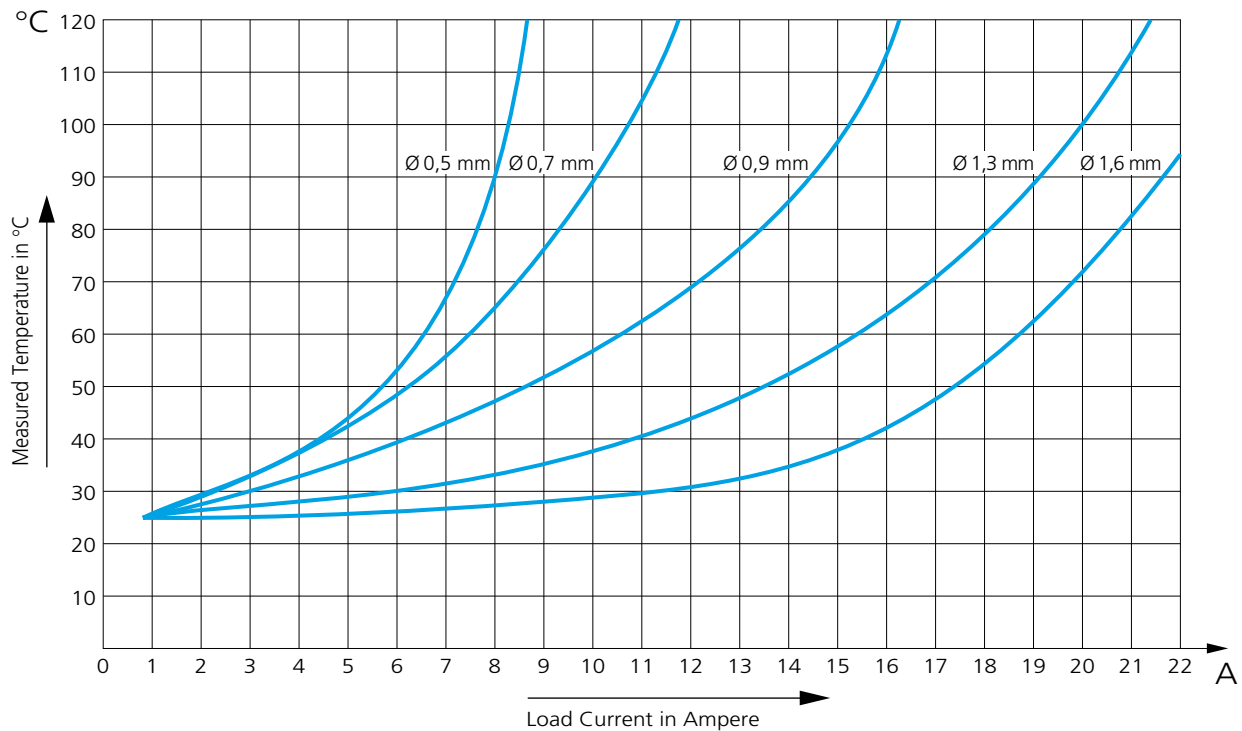

➔ **Maximum operating temperature for Standard Contacts: +120 °C**

Test contact was terminated to largest possible conductor.

Connectors or cables with more than one contact or conductor generate a higher heat than a single contact. Therefore, a **Derating Factor** must be applied. For connectors the Derating Factor is applied according to DIN 57 298 Teil 4 / VDE 0298 Teil 2. The Derating Factor is used starting with 5 loaded wires (DIN 41 640 T3).

#### Derating Factor:

Number of loaded wires	Derating Factor
5	0.75
7	0.65
10	0.55
14	0.50
19	0.45
24	0.40

## Termination Styles

Contact blocks (insulation bodies with contacts) are interchangeable between receptacle and plug. As a rule the socket contact blocks are mounted in the part under power.

ODU offers the following contact termination styles:

- **Solder**
- **Crimp**
- **PCB**

## Termination Styles for Turned Contacts

### Solder Termination:

The contacts come mounted by the factory. The insulation body and the pre-assembled contacts are called a contact block.



### Crimp Termination

A single contact is crimped to a single conductor. Subsequently, the crimped contact is pushed into the insulation body. Crimp contacts and insulation bodies are shipped separately.

Crimping creates a reliable, corrosion-free and durable connection between the contact and the conductor.

Crimping causes the crimp barrel of the contact and the conductor material to cold flow. It creates a gas-tight connection between contact and conductor.

The ODU MINI-SNAP generally requires the industry-standard 8-point crimp tool .



Crimp-Clip-Contact for PEEK insulator

### Printed Circuit Board (PCB) Termination:

PCB pins are used only for receptacles which are mounted directly to the PCB. The contacts are permanently installed in the insulation body.



## Conversion AWG - Cross Section

### AWG = American Wire Gauge

The AWG system describes the cross section of a wire using a gauge number for every 26 % increase in conductor cross section. With larger wire diameters, the AWG gauge numbers decrease; as the wire sizes increase, the AWG gauge numbers decrease.

Most wires are made with **stranded conductors**. Compared to solid conductors stranded wires offer higher durability, higher flexibility and better performance under bending and vibration.

Stranded wires are made from wires with smaller gauge sizes (higher AWG gauge number). The AWG gauge number of the stranded wire is equal to that of a solid conductor of the same size wire. The cross section of the stranded conductor is the sum of cross sections of the single conductors.

For example, a AWG-20 stranded wire of 7 AWG-28 conductors has a cross section of 0.563 mm<sup>2</sup>; an AWG-20 stranded wire with 19 AWG-32 conductors has a cross section of 0.616 mm<sup>2</sup>.

Conversion Table AWG / mm<sup>2</sup>

Circular Conductor			
AWG	Diameter		Cross Section mm <sup>2</sup>
	in	mm	
10 (1)	0.102	2.59	5.27
10 (37/26)	1.109	2.75	4.53
12 (1)	0.0808	2.05	3.31
12 (19/25)	0.0895	2.25	3.08
12 (37/28)	0.0858	2.18	2.97
14 (1)	0.0641	1.63	2.08
14 (19/27)	0.0670	1.70	1.94
14 (37/30)	0.0673	1.71	1.87
16 (1)	0.0508	1.29	1.31
16 (19/29)	0.0551	1.40	1.23
18 (1)	0.0403	1.02	0.82
18 (19/30)	0.0480	1.22	0.96
20 (1)	0.032	0.813	0.52
20 (7/28)	0.0366	0.93	0.56
20 (19/32)	0.0384	0.98	0.62
22 (1)	0.0252	0.64	0.324
22 (7/30)	0.0288	0.731	0.354
22 (19/34)	0.0307	0.780	0.382
24 (1)	0.0197	0.50	0.196
24 (7/32)	0.023	0.585	0.227
24 (19/36)	0.0252	0.640	0.240
26 (1)	0.157	0.40	0.122
26 (7/34)	0.0189	0.48	0.140
26 (19/38)	0.0192	0.487	0.15
28 (1)	0.0126	0.32	0.08
28 (7/36)	0.015	0.381	0.089
28 (19/40)	0.0151	0.385	0.095
30 (1)	0.0098	0.250	0.0506
30 (7/38)	0.0115	0.293	0.055
30 (19/42)	0.0123	0.312	0.072
32 (1)	0.0080	0.203	0.032
32 (7/40)	0.0094	0.240	0.035
32 (19/44)	0.0100	0.254	0.044
34 (1)	0.0063	0.160	0.0201
34 (7/42)	0.0083	0.211	0.0266
36 (1)	0.0050	0.127	0.0127
36 (7/44)	0.0064	0.163	0.0161
38 (1)	0.0040	0.100	0.0078
40 (1)	0.0031	0.080	0.0050
42 (1)	0.0028	0.0700	0.0038
44 (1)	0.0021	0.054	0.0023

(Font: Gore & Associates, Pleinfeld)

## Housing Materials and Surface Finish

MINI-SNAP housings are made from brass and are nickel-plated with a matt-chromate surface finish (sand-blasted). Nickel-plated or black chromate-finished housings are available on special request.

Inside metal components are made from nickel-plated brass.

Component Parts	Material	Surface
	Designation	Thickness of the film
Housing Back Nut Slotted Nut	➔ Cu-alloy	+ 1 µm Cu + 3–6 µm Ni + 0.3–1 µm matt chromate
Collet EMI-Ring Half-Shells Locking Washer Nut Retainer Ring	➔ Cu-alloy	➔ Ni matt: 6–8 µm
Pin (solder or PCB) Socket (solder or PCB) Pin (crimp) Socket (crimp)	➔ Cu-alloy	+ 1.25 µm Ni ➔ + 0.75 µm Au

## Insulation Body Material ( recognized)

	Norm		Unit	PBT	PTFE 1)	PEEK
<b>Dialectric Strength</b>	DIN 53481	ASTM D-149	KV / mm	27	> 50	19
<b>Operating Temperature</b>	--	--	°C	-40/+140	-100/+260	-50/+250
<b>Flammability rating</b>	UL-94	--	--	V-0	V-0	V-0
<b>Creeping distance acc. to CTI</b>	IEC 60112			275	600	175

<sup>1)</sup> PTFE (Teflon) is only used for Coax- and Triax Connectors

## Electromagnetic Compatibility (EMC)

When discussing electromagnetic compatibility (EMC) one should not only consider the device or the circuit, but also include the network and the entire data communication link. This involves all connecting elements such as conductors and connectors. Electromagnetic interference from the outside into the connector can lead to system malfunctioning. The best way to prevent this is by providing a high-quality shield between the cable and the connector. In order to provide reliable EMC data to our customers we engaged the services of a certified test laboratory to investigate the EMC characteristics of the ODU MINI-SNAP. They tested for us Size 00, 0, 1, 2 and 3 MINI-SNAP connectors.

Measurements were conducted using the inductive wire or parallel wire method in accordance with test procedure VG 55214-6-2. In this set-up, the mated connector is connected on one end to a network analyzer and terminated on the other end with a suitable impedance. The inductive wire is then mounted in close proximity along the mated connector pair. The induction wire is a ribbon cable which permits to vary the level of induction by using more or less of the ribbon conductors.

Next, a signal with a frequency range of 10 kHz to 3 GHz is connected to the ribbon cable. The network analyzer is used to measure the amount of signal induced into the connector circuit. The result is shown as the shielding attenuation  $A_T$  in dB. It is essential that all leads to the connector are shielded so that no signal can be induced into the circuit at any other place except the connector. The various attenuation values are plotted on a logarithmic scale as attenuation in dB vs. frequency.

An attenuation of better than -55 dB is generally required for reliable connector and system operation. It can be shown that our connectors will meet this requirement in all applications.

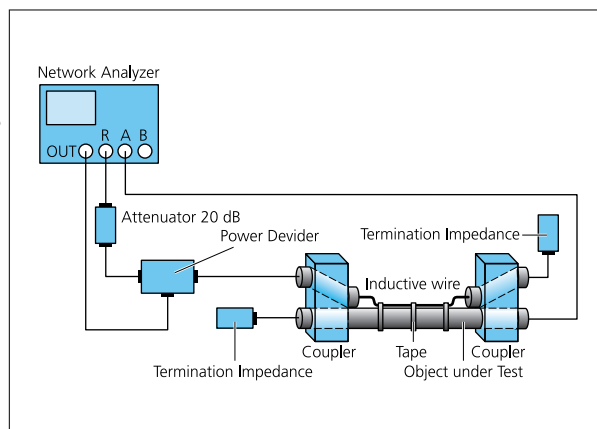

The following diagram is valid for all series and standard sizes.

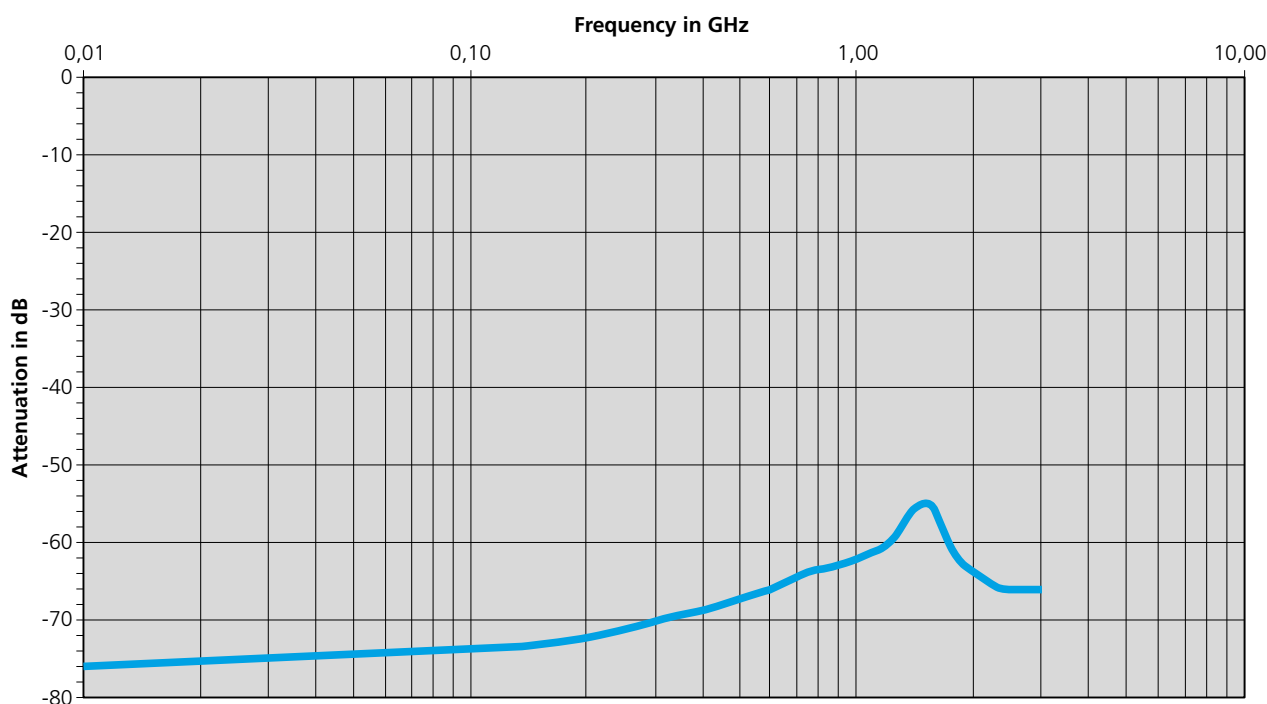

## Autoclaving of ODU MINI-SNAP Connectors

If required ODU can deliver MINI-SNAP connectors for the following sterilization process: Steam-sterilization with pre-vacuum or gravitation-process. Connectors were tested with autoklave equipment with reference to DIN EN 13 060 at 134° C and 500 cycles.

### Sterilization Curve:

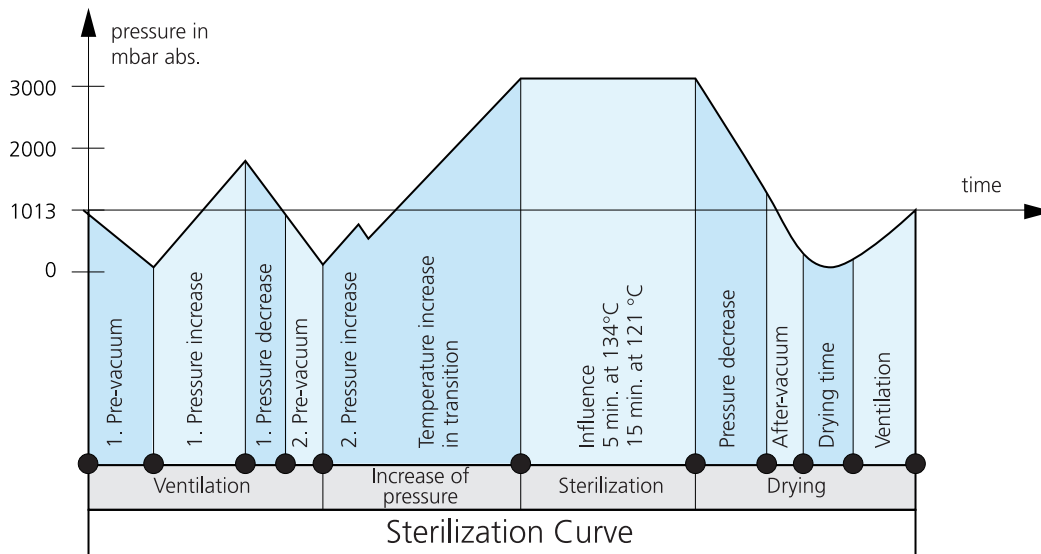

For other sterilization-processes please contact our technical support team.



In the scope of quality approval the sizes 0 and 3 have been submitted to environmental and mechanical tests acc. to MIL.

All tests have been passed.

**Tests carried out:**

<b>Definition</b>	<b>Nach Norm</b>
High Temperature	MIL-STD 810 F / PV 501
Low Temperature	MIL-STD 810 F / PV 502
Temperature Shock	MIL-STD 810 F / PV 503
Humidity	MIL-STD 810 F / PV 507
Salt Fog	MIL-STD 810 F / PV 509 and MIL-STD 1344 A / Methode 1001.1
Shock	MIL-STD 810 F / PV 516
Vibration	MIL-STD 1344 A / Methode 2005.1 / IV
Water Thightness IP 68	IEC 60529

## Technical Terms and Definitions

### **Air Gap**

= Shortest distance between two conductive elements through the air.

### **Autoclavability**

(See page 130)

### **AWG**

(See page 127)

### **Creepage Distance**

= The distance measured across the surface of a dielectric between two contacts or a contact and a metal part. The longer the distance, the lesser the risk of damage or tracking. Minimum creepage distances are specified according to the operating voltage and the applicable isolation group.

### **Crimp Area**

= The part of a crimp barrel at which the crimp connection is achieved by pressure deformation or by reshaping the barrel around the conductor.

### **Crimp Barrel**

A hollow part of a contact which accepts one or more conductors and which may be crimped through the application of a crimping tool.

### **Crimp Connection**

= The permanent attachment of a contact to a conductor by pressure deformation or by reshaping the crimp barrel around the conductor so that a good electrical and mechanical connection is established.

(See page 126)

### **Connector**

= A component which terminates conductors for the purpose of providing connection and disconnection to a suitable mating component. Depending on the fastening to a cabinet, panel, rack etc. or a cable, they are classification.

### **Delivery**

Delivery of the connectors usually as components (that means not assembled).

Exception: Solder contacts are factory-installed in the insulation body.

### **Fixed Connector**

= A connector for attachment to a rigid surface (panel).

### **Free Connector**

= A connector for attachment to the free end of a wire or cable. Also called free hanging connector or inline receptacle.

### **Insertion Or Withdrawal Force**

= The force required to fully mate or unmate a set of connectors without the effect of coupling, locking or similar devices. The insertion force is usually greater than the withdrawal force. Also called mating and unmating force.

### **Insulation Body**

= Non-conductive part of a connector, to electrically and mechanically separate live parts and to protect against accidental touch.

### **Insulation Group**

= Classification of connectors according to the operating and working conditions (insulation groups according DIN VDE 0110).

**Keying**

= System of projections and grooves on mating connectors which prevent otherwise identical connectors from being mated. This is useful when several connectors of the same style are used in the same application (see page 30, 50, 66).

**Lower Limit Temperature**

= The lowest permissible temperature which a connector or a plug-in device is allowed to be operated.

**Materials**

The contacts are made of Cu-alloy and gold-plated. The standard housings are made of Cu-alloy with a matt-chromate surface finish. All other materials and surfaces on special request. (see page 128).

**Mating Cycles**

= Mechanical operation of connectors and plug-in devices by insertion and withdrawal. One mating cycle comprises one insertion and one withdrawal operation.

**Nominal Single Contact Current Load**

= Current load, which can load every single contact (see page 125).

**Nominal Voltage**

Nominal voltage characterizes a component.

**Operating Temperature of the ODU MINI-SNAP**

= Range between upper and lower temperature limits.  
-40°C to +120°C (see page 8)

**Print Connection**

(see page 126)

**Printed Circuit Board**

Boards, typically made of epoxy-filled glass fiber fabric, with conductive pattern on one or both sides, or in case of multilayer boards, also imbedded inside the board. They feature metallized holes for soldering wire-mounted components or for the insertion of resilient or rigid press-in pins or instead, pads for attaching components using surface mount technology (SMT).

**Reference Current**

= The current at which a connector can be operated permanently simultaneously through all contacts without reaching maximum temperature.

**Reference Voltage**

Normal voltage (VDE 0110) for a connector.

**Solder Termination**

(see page 126 Termination Styles)

**Termination techniques**

= Methods for connecting a wire to an electro-mechanical component, e.g. solderless connection according to IEC 60352: respectively such as crimp, press-in etc. or solder connections.

**Test Voltage**

= The voltage the connectors are tested, and are being referred on definite characteristics.

**Upper Limit Temperature**

= highest permissible temperature at which a connector or a plug-in device is allowed to operate. This temperature includes the self-heating and the ambient temperature. At ODU MINI-SNAP + 120 °C (see page 125).

**Watertightness**

(See page 123)

**Wire**

= Wires may be provided with an insulation cover, an electrical shielding. Cables or conductors may consist of one or more wires.

Connectors shown in this catalog are designed to operate at high voltages and high frequencies. Care must be taken to assure that no person can come in contact with live conductors during installation or operation of the connectors.

ODU reserves the right to change design and performance of any product to meet changing technical developments without prior notice. ODU reserves the right to discontinue any part in this catalog without prior notice and without obligation to continue production after the change.

# Please visit us in the Internet

[www.odu.de](http://www.odu.de)  
[www.odu-automotive.com](http://www.odu-automotive.com)  
[www.odu-usa.com](http://www.odu-usa.com)  
[www.odu-china.com](http://www.odu-china.com)



On our website you can find a lot of applications. For example: Medical, Measurement and Testing, Telecommunication, Industrial Electronic, etc. .



## More Push-Pull Series from ODU

### ODU MINI-SNAP Series S



Cylindrical Connector made out of metal with push-pull locking – FP locking principle using conical sleeve, Keying with insulator.

### ODU MINI-SNAP Series F



Cylindrical Connector made out of metal with push-pull locking – FP locking principle using conical sleeve, Keying with half-shells.

### ODU MINI-SNAP PC



Cylindrical Connector made out of plastic with push-pull locking – FP locking principle using conical sleeve, Keying with half-shells.

### ODU MEDI-SNAP



Cylindrical Connector made out of plastic with push-pull locking – especially for the medical industry.



Please open

# The Part Number Key

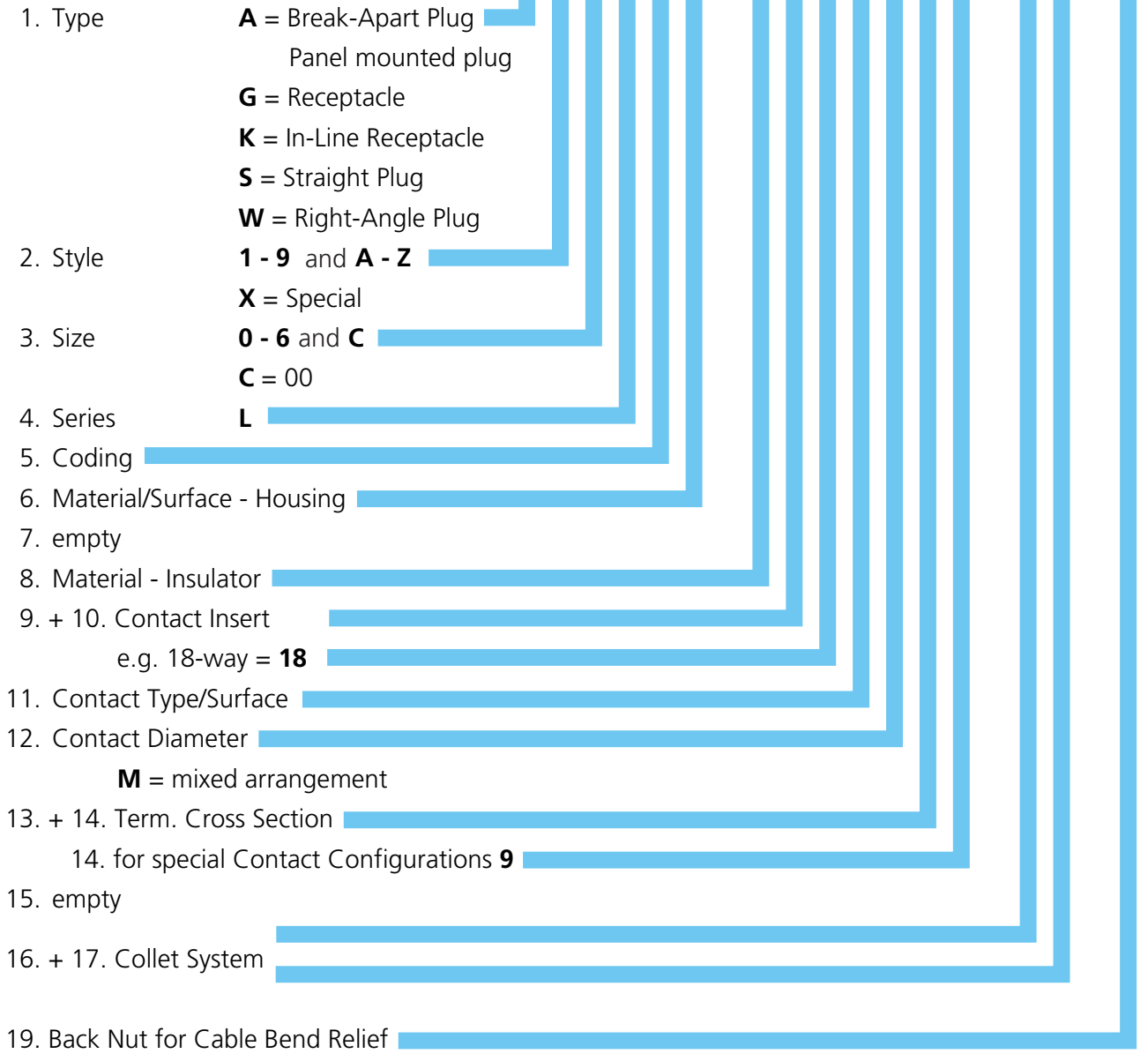
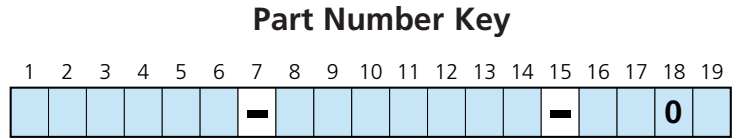

**Example:**

1	2	3	4	5	6	7	8	9	10	11	12	13	14	15	16	17	18	19
<b>G</b>	<b>5</b>	<b>2</b>	<b>L</b>	<b>0</b>	<b>C</b>	<b>-</b>	<b>P</b>	<b>1</b>	<b>6</b>	<b>N</b>	<b>F</b>	<b>G</b>	<b>0</b>	<b>-</b>	<b>0</b>	<b>0</b>	<b>0</b>	<b>0</b>

Receptacle – Style 5 – Size 2 – Series L – Coding 60° – Brass matt chromate Housing – PBT Insulator – 16-pos. – Socket(crimp) 0.75 µm Au – Term. Cross Section AWG22

1	2	3	4	5	6	7	8	9	10	11	12	13	14	15	16	17	18	19
<b>S</b>	<b>2</b>	<b>2</b>	<b>L</b>	<b>0</b>	<b>C</b>	<b>-</b>	<b>P</b>	<b>1</b>	<b>6</b>	<b>M</b>	<b>F</b>	<b>G</b>	<b>0</b>	<b>-</b>	<b>7</b>	<b>2</b>	<b>0</b>	<b>S</b>

Plug – Style 2 – Size 2 – Series L – Coding 60° – Brass matt chromate Housing – PEEK Insulator – 16-pos. – Pin (solder) 0.75 µm Au – Term. Cross Section AWG22 - Cable Diameter 6.0–7.2 mm – Back Nut for Silicone Cable Bend Relief (to order separtly)



# TELEFAX-INQUIRY ODU MINI-SNAP

Fax-No. **08631/61 56-49 z. Hd. Vertrieb ODU MINI-SNAP**  
**ODU-Steckverbindingssysteme GmbH & Co. KG**  
 Pregelstr. 11  
 D-84453 Mühldorf am Inn

From:

Company:	_____
Name:	_____
Dept.:	_____
Street:	_____
City:	_____
Phone:	_____ Date: _____

## ODU MINI-SNAP Summary of Technical Requirements

1) Connector application	: _____
2) Environment	: _____
3) Connector Type	: <input type="checkbox"/> Plug <input type="checkbox"/> Receptacle <input type="checkbox"/> Inline Receptacle <input type="checkbox"/> 90° Plug <input type="checkbox"/> 90° receptacle
4) Special Version	: _____
5) Style	: _____
6) Size	: <input type="checkbox"/> 00 <input type="checkbox"/> 0 <input type="checkbox"/> 1 <input type="checkbox"/> 2 <input type="checkbox"/> 3 <input type="checkbox"/> 4 <input type="checkbox"/> 5 <input type="checkbox"/> 6
7) Series	: <input type="checkbox"/> don't care <input type="checkbox"/> L <input type="checkbox"/> K <input type="checkbox"/> B
8) Keying	: _____
9) Number of Positions	: _____
10) Termination	: <input type="checkbox"/> solder <input type="checkbox"/> crimp <input type="checkbox"/> PCB
11) Cross section of wire	: _____ mm <sup>2</sup> _____ AWG
12) Cable Dia.	: _____ mm
13) Bend Sleeve (color)	: _____
14) Protection DIN EN 60 529	: <input type="checkbox"/> IP 50 (Standard) <input type="checkbox"/> IP 68 (watertight) <input type="checkbox"/> other _____
15) Operating Temperature	: _____ °C max.   _____ °C min.
16) Electrical Specs:	
Operating Voltage	: _____ V AC   _____ V DC
Operating Current	: Constant _____ A   Short-term _____ A, _____ sec.
17) Chemical resistance against	: _____
18) Other requirements	: _____
19) Autoclavable, +134° C (see page 130)	: <input type="checkbox"/> Yes <input type="checkbox"/> No
↪ Number required	: _____
↪ Production Quantity	: _____

**ODU worldwide**



ODU Steckverbindingssysteme  
GmbH & Co. KG  
Otto Dunkel GmbH  
Pregelstr. 11  
84453 Mühldorf a. Inn  
Germany  
Phone: +49/86 31/6156-0  
Fax: +49/86 31/6156-49  
E-Mail: zentral@odu.de  
Internet: www.odu.de

ODU France  
Phone: +33/1/39 35-46 90  
E-Mail: jean-nicolas.vikelas@odu.fr

ODU Scandinavia  
Phone: +46/1 76/1 82 61  
E-Mail: peter.biloch@odu.se

ODU UK  
Phone: +44/15 09-2 66-4 33  
E-Mail: sales@odu-uk.co.uk

ODU USA  
Phone: +1/8 05/4 84 05 40  
E-Mail: sales@odu-usa.com

ODU Shanghai Trading  
Phone: +86/21/58 34 78 28-106  
E-Mail: oduchina@odu.com.cn



ODU's headquarters and factory are located in Mühldorf at the river Inn, approximately 50 miles east of Munich, at the foothills of the Bavarian Alps.



PEFC™ Advancement of sustainable wood cultivation.  
PEFC/04-31-1083