

M-Series Analog

Temposonics MS
Measuring range 50 - 2000 mm

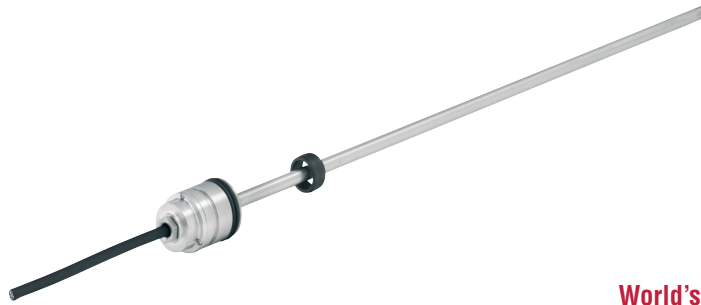

World's smallest Mobile Hydraulics Sensor

- Linear, Absolute Measurement in Hydraulic Cylinders
- Contactless Sensing with Highest Durability
- Minor Dimensions for Compact Mobile Hydrocylinders
- Replacing Potentiometers and Inductive Position Sensors
- Superior Accuracy: Linearity Tolerance better 0,04 %
- Repeatability 0,005 %
- Direct Analog Displacement Output
- Power Supply: 12 VDC
- EMC: Immunity against electromagnetic HF-fields up to 100 V/m
- Independent from Hydraulic Liquid

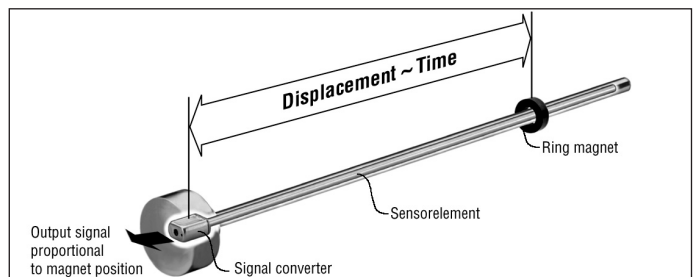

Magnetostriction

Form factor

The absolute **Temposonics®** linear position sensors are based on the MTS developed magnetostrictive measurement principle. That combines various magneto-mechanical effects and uses the physical height precise speed-measurement of an ultrasonic wave (torsion pulse in its sensor element) for position detecting. Sensor integrated signal processing transforms the measurements directly into market standard outputs. The contactless principle - an external movable magnet marks the position - eliminates the wear, noise and erroneous signal problems and guarantees the best durability without any recalibration.

Temposonics® MS, the compact stainless steel position sensor is designed for installation into hydraulic cylinders, specifically for use in clevis head mobile cylinders or any space limited cylinder applications.

1. The sensor head, a robust housing with built-in electronics.
2. The pressure-proof sensor pipe with flange protects the internal sensing element, the waveguide system. It fits into the bored piston rod.
3. The position magnet, only moving part is mounted on the piston bottom. This permanent magnet travels wearfree and contactless along the stationary sensor tube. Its magnetic field starts the measurement signal through the sensor's rod wall.

Temposonics-MS

Analog

Temposonics-MS - High Pressure Compact Sensor Measuring Range 50 - 2000 mm.

Temposonics-MS, the new compact stainless steel position sensor is designed for installation into hydraulic cylinders, specifically for use in clevis head mobile cylinders or any space limited cylinder applications.

MS type sensors are ideal choices for a wide range of standard hydraulic cylinders. Magnetostrictive displacement sensors, high quality cylinders and precise control valves form ideal driving systems for technically demanding of mobile hydraulics.

Analog Output

Temposonics-MS sensors provide analog output of 0 - 5 V. The analog output signal is proportional to the magnet position along the active measuring sensor stroke. The measuring range is factory set and does not need recalibration. Since the outputs are direct, no signal-conditioning electronics are needed when interfacing with controllers or meters.

Technical Data

Input	
Measured Variables:	Displacement
Measuring Range:	50 - 2000 mm in 5 mm steps
Output	
Voltage:	0 - 5 VDC / 0,25... 4,75 / 0,5 ... 4,5 VDC; (Controller input resistance $R_L \geq 10 \text{ k}\Omega$ short circuit-proof, electric strength up to 28 Vdc)
Strom:	4 - 20 mA (apparent power of the voltage transformer $\leq 250 \text{ Ohm}$ with 12 V power supply)
Accuracy	
Resolution:	Infinite, restricted by output ripple
Linearity, uncorrected:	$< \pm 0,04 \%$ F.S. (Minimum $\pm 0,100 \text{ mm}$)
Repeatability:	$< \pm 0,005 \%$ F.S.
Update Frequency:	$> 488 \text{ Hz}$
Ripple:	$< 0,04 \%$ F.S.
Setting points:	$\pm 0,7 \text{ mm}$
Operating conditions	
Mounting Position, Sensor:	Any orientation
Magnet Speed:	Any
Operating Temperature:	$-40^\circ \text{ C} \dots +85^\circ \text{ C}$
Dew Point, Humidity:	90 % rel. humidity, no condensation
Sealing:	IP 65
Rod Pressure Rating:	300 bar, 450 bar peak pressure for 7 mm rod diameter
Shock Rating:	100 g (single hit) / IEC-Standard 68-2-27
Vibration Rating:	15 g / 10 - 2000 Hz / IEC-Standard 68-2-6
EMC-Test:	Immunity belong to ISO 11452-5: electromagnetic HF-fields up to 100 V/m CE certified
Form factor, Material	
Material Sensor:	Stainless steel 1.4305 / AISI 304
Magnet Type:	Ring magnet
Installation	
Mounting:	Clearance fit flange $\varnothing 28 \text{ mm}$
Electrical connections	
Connection Type:	pigttailed PUR cable
Input Voltage:	12 VDC (10 - 16 V)
Ripple:	$< 1 \%$ peak to peak
Current Drain:	$< 80 \text{ mA}$
Electric Strength:	500 V (0 V ground to machine ground)
Polarity Protection:	Up to -36 VDC
Overvoltage Protection:	Up to 36 VDC

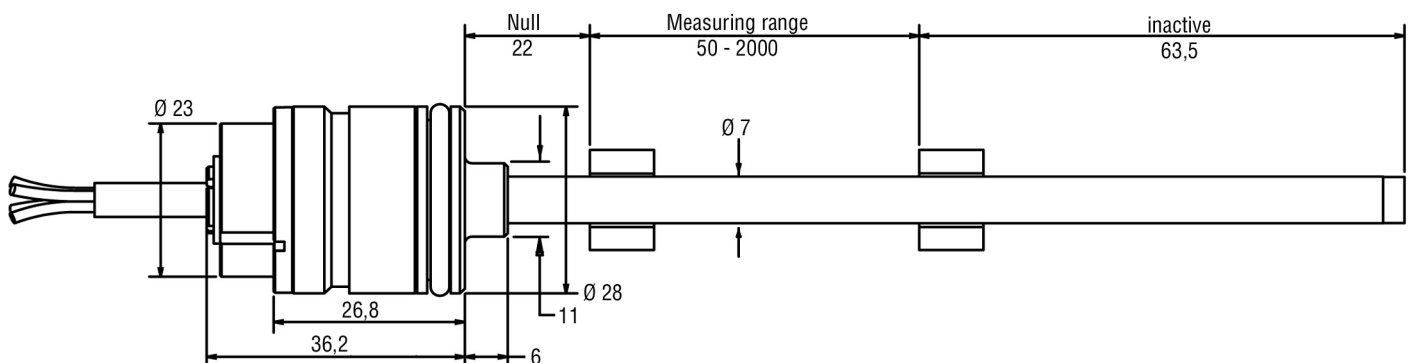

Measurement in mm. Technical alterations reserved

Positionsgeber

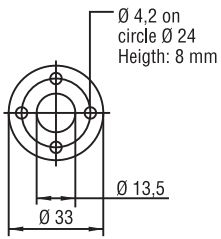

Ring magnet OD33
Part No. 201 542-2

PA-Ferrit-GF20
Weight ca. 14g
Operating temperature:
-40 ... +100°C
Surface pressure max. 40 N/mm² in axial direction
Fastening Torque for M4 screws max. 1 Nm

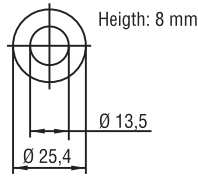

Ring magnet OD25,4
Part No. 400 533

Composite PA-Ferrite-GF20
Weight ca. 14g
Operating temperature:
-40 ... +100°C
Surface pressure max. 40 N/mm² in axial direction

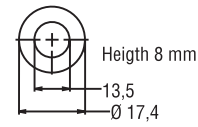

Ring magnet OD17,4
Part No. 401 032

Composite PA-Ferrite
Weight ca. 10g
Operating temperature:
-40 ... +100°C
Surface pressure max. 10 N/mm² in axial direction

Cable outlet

PUR-cable, 4 x 0,25 mm², Ø ~ 5 mm,
flexible, oil resisting

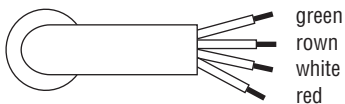

Wiring

Wire color	Signal
green	Output: Voltage range
brown	+12VDC
white	DC Ground (0V)
red	n.c.

Installation

The robust Temposonics-MS sensor is due to its form factor, excellently suited for direct stroke measurement in standard compact fluid-cylinders.

The position magnet, mounted on the piston bottom, drives contactlessly along the measuring stroke and marks exactly the position through the rod wall - independent of the used hydraulic fluid - that guarantees a longlife and trouble-free operation.

Sensor

The stainless steel rod model sensor can be mounted in any position via the clearance fit flange Ø 28 mm.

Hydraulic sealing is by using an O-Ring and Backup-Ring in housing channel. Non-magnetizable material should be used for the sensor mounting component. Taking the mounting dimensions shown below into account is indispensable.

Position Magnet

To have a neat magnetic field for measuring, non-magnetizable material must be used for the position magnet mounting components (screws, spacers, retaining ring etc.).

For further details according to cylinder design please contact directly MTS.

Installation Versions

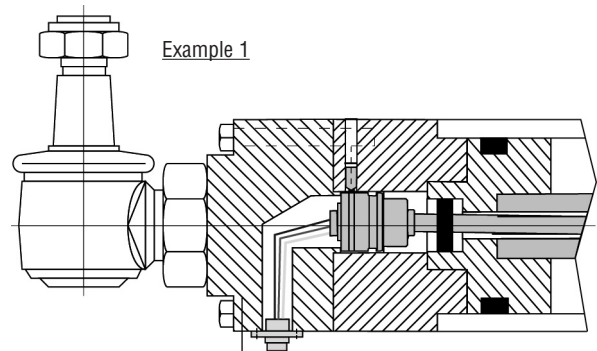

Example 2

The sensor will be fixed with setscrew

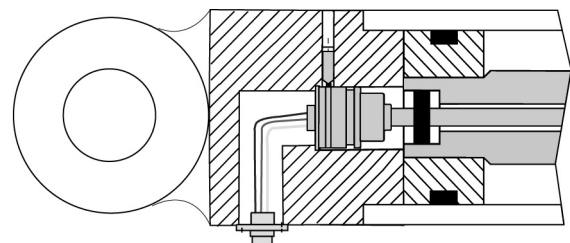

Non-magnetizable material

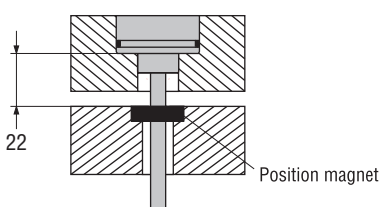

Magnetizable material

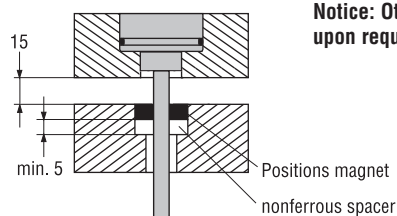

Notice: Other installation versions upon request!

Measurement in mm. Technical alterations reserved

Temposonics-MS

Analog

Installation Notes

- Use a rod bush (e.g. teflon) to prevent wear on the magnet and the sensor pipe.
- The bore in the piston rod is dependent on hydraulic pressure and piston velocity etc. The minimum drilling must be 10 (7 mm rod)
- Do not exceed the peak pressure.

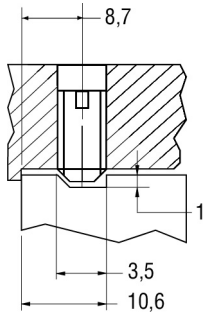

e.g. retaining with set screw DIN 913 M5x10, thread end with flat point maximum torque 0,5 Nm

Detail Flange housing

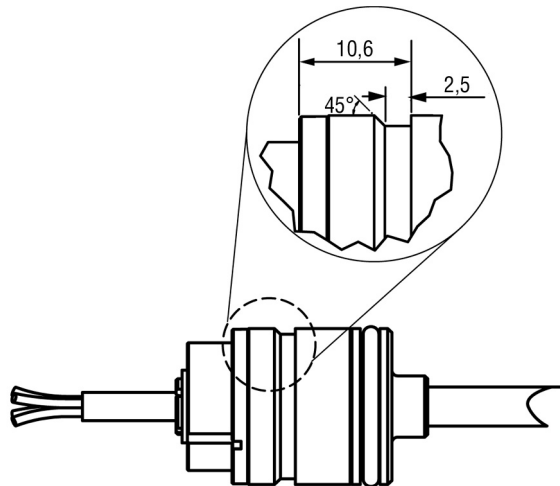

Measurement in mm. Technical alterations reserved

Temposonics

M S ■ ■ ■ ■ ■ **M** **T X Y** **A** **3** ■ ■ ■

MS = Hydraulic Rod Ø 7mm
Flange housing Ø 28 mm

Measuring range
0050 - 2000 mm in 5 mm steps

Connection type
T = PUR-Cable 4 x 0,25 mm², screened -40 - 105°C
X = m, cable length 0 - 9 m
Y = 0,1 m, cable length 0,1 - 0,9 m

Operating cable end
A = pigtailed

Input voltage
3 = +12 VDC

Output
V10 = 0 - 5 V
V11 = 0,25 - 4,75 V
A01 = 4 - 20 mA

Asseccories (selection)

Ring magnet OD33
Ring magnet OD25,4
Ring magnet OD17,4

Part No.

201 542-2
400 533
401 032

Scope of Delivery

- Position Sensor
- O-Ring
- Backup-Ring

Pls. order magnets separately.

www.mtssensor.de
www.temposonics-shop.de
Service Hotline: 01805 - mtssensor

© MTS Temposonics® M-Series Temposonics MS Analog 14112006e - Alterations reserved

MTS
SENSORS

Deutschland
MTS Sensor Technologie
GmbH & Co. KG
Auf dem Schüffel 9
D-58513 Lüdenscheid
Tel.: +49-2351-9587-0
Fax: +49-2351-56491
info@mtssensor.de
www.mtssensor.de

USA
MTS Systems Corporation
Sensors Division
3001 Sheldon Drive
Cary, NC 27513, USA
Tel.: +1-919-677-0100
Fax: +1-919-677-0200
info@mtssensors.com
www.mtssensors.com

Japan
MTS Sensors Technology Corp.
Ushikubo Bldg.
737 Aihara-cho, Machida-shi
Tokyo 194-0211, Japan
Tel.: +81-42-775-3838
Fax: +81-42-775-5516
info@mtssensor.co.jp
www.mtssensor.co.jp